

12-1-1980

## Volume 4, Number 12 (December 1980)

The Solar Ocean Energy Liaison

Follow this and additional works at: [https://nsuworks.nova.edu/nsudigital\\_otec-liaison](https://nsuworks.nova.edu/nsudigital_otec-liaison)

 Part of the [Energy Policy Commons](#), [Environmental Studies Commons](#), [Natural Resources Management and Policy Commons](#), [Oceanography Commons](#), [Oil, Gas, and Energy Commons](#), [Science and Technology Studies Commons](#), and the [Water Resource Management Commons](#)

---

### NSUWorks Citation

The Solar Ocean Energy Liaison, "Volume 4, Number 12 (December 1980)" (1980). *The OTEC Liaison*. 40.  
[https://nsuworks.nova.edu/nsudigital\\_otec-liaison/40](https://nsuworks.nova.edu/nsudigital_otec-liaison/40)

This Newsletter is brought to you for free and open access by the NSU Digital Collections at NSUWorks. It has been accepted for inclusion in The OTEC Liaison by an authorized administrator of NSUWorks. For more information, please contact [nsuworks@nova.edu](mailto:nsuworks@nova.edu).

# Solar OCEAN ENERGY Liaison

INCORPORATING  
The OTEC Liaison

VOLUME 4 NUMBER 12  
December 1980

## US VIRGIN ISLANDS PRIME OTEC SITE Combined OTEC/Desalinization Plant Proposed at December Conference

Over 40 ocean scientists from Europe, the United States, and the Virgin Islands were in attendance at the OTEC WORKSHOP held in St. Croix, USVI November 10th through 12th, hosted by the Virgin Islands Energy Office (VIEO). Attendees included Swedish and Finnish representatives as well as individuals long active in the OTEC community, such as Brian Coffay (Westinghouse), Donald Sasscer (the University of Puerto Rico), Robert Fulton and William Rogalski (Gibbs and Cox), Oswald Roels (the University of Texas), and Malcolm Jones (Reynolds Metals). [The two latter persons have new affiliations since the St. Croix meeting: See "NAMES IN THE NEWS" elsewhere in this issue.]

Arranged and chaired by the Director of VIEO, Dr. Frank Prince, the meeting was highlighted by presentations by Bengt Lindqvist and Bo Broms, representing a Scandinavian consortium known as *The Swedish OTEC-Nord-Aqua Group*, or just *Nord-Aqua* for short. Their presentations

included the description of a proposed desalinization-OTEC plant with possible inclusion of mariculture specifically designed for potential sites at St. Croix. A technical description of this proposal may be found elsewhere in this issue.

### Identical Conclusion in MARAD Study

Following the formal presentation on *Closed/Open-Cycle OTEC* by Brian Coffay, an open discussion among the attendees brought out the fact that a Westinghouse study for the Maritime Administration (MARAD), an agency of the US Department of Commerce, had come to almost the same conclusion as Nord-Aqua: that a closed-cycle OTEC plant combined with a multi-stage flash evaporator for production of fresh water, *with St. Croix as the ideal site*, was economically feasible.

[*A Study to Determine the Commercialization Potential of Open-Cycle OTEC Water Plants*, authored by Brian Coffay of

### OTEC-1 LOOKING GOOD!

Reports on start-up operations of the OTEC-1 test platform off the coast of Hawaii indicate that operators are making excellent progress.

Early results indicate that biofouling is currently "insignificant" and that heat-transfer coefficients are "better than expected".

A more detailed report will appear in our January issue.

the Steam Turbine-Generator Technical Operations Division of the Power Systems Company of Westinghouse Electric Corporation, Lester, Pennsylvania—prepared for MARAD and dated July 1980—is available from the National Technical Information Service, Springfield, Virginia 22161. Specify Document PB80 19 9060, \$21.]

The study states that "this process appears to offer economic advantages over the open-cycle process for small seawater desalinization facilities as well as an advantage of being able to be deployed sooner".

From a candidate list of potential sites which included all states, Puerto Rico, the US Virgin Islands, Guam, American Samoa, and the Northern Mariana Islands, candidate sites were narrowed down to four: the south coast of Puerto Rico, the Virgin Islands, and the Hawaiian islands of Oahu and Hawaii. Of these, St. Croix was selected as the most favorable site for reasons including those that follow.

**THERMAL RESOURCE:** Temperature profiles for one St. Croix site ranged from an annual low delta-T of 18.6°C at 700 meters to an annual high of 23.2°C at 900 meters.

**NEED FOR FRESH WATER:** The islands of St. Thomas and St. Croix have already experienced the water shortages and high costs necessary to make OTEC-produced fresh water economically attractive. The most crucial commodity on these islands is fresh water. Wells are rarely filled by catchments built to trap rainwater, and four seawater desalinization plants suffer chronic breakdowns. The barging of water from Puerto Rico, begun in 1955, adds to



The pleasant shirt-sleeve environment above was the site of the OTEC WORKSHOP held at St. Croix, USVI November 10th and 11th. The energy-rich Caribbean Sea lies a scant fifty feet to the right, waiting to be tapped.

(continued on Page 3)

# Solar OCEAN ENERGY Liaison

INCORPORATING  
The OTEC Liaison

AN INTERNATIONAL NEWSLETTER  
ENGAGED AS LIAISON FOR ALL  
FORMS OF SOLAR ENERGY FROM  
THE SEA, INCLUDING:

OTEC  
(OCEAN THERMAL  
ENERGY CONVERSION)  
WAVE - TIDAL - CURRENT  
OFFSHORE WIND - BIOMASS  
SALINITY GRADIENTS

VOLUME 4 NUMBER 12  
December 1980

EDITOR/PUBLISHER  
Richard Arlen Meyer

TYPESETTER  
AND COPY EDITOR  
Shelly Treshansky

ART DIRECTOR  
Pamela Greenfield

BUSINESS MANAGER  
Kathleen Guido

SUBSCRIPTION MANAGER  
Mildred Ward

Solar OCEAN ENERGY Liaison is published monthly by Popular Products Incorporated at 1303 South Michigan Avenue, Chicago, Illinois 60605, USA. Phone (312) 427-3000. Printed in USA. Copyright 1980 by Popular Products Incorporated, Chicago, Illinois. All rights reserved. Contents of this newsletter may not be reproduced either in whole or in part without permission. Solar OCEAN ENERGY Liaison will not assume any responsibility for manuscripts or photos either left or submitted on speculation. Subscription prices are listed below: United States and possessions: one year \$125, two years \$200. Foreign: Add \$15 per year for air mail. Single copies: US \$10.50 per copy. Foreign \$11.25 per copy. ISSN: 0162-8755



**SOLAR OCEAN ENERGY**

## HAWAIIAN SEACOAST TEST FACILITY EXPECTED TO HAVE LITTLE ENVIRONMENTAL IMPACT

The Department of Energy (DOE) has completed an environmental assessment of the first stage of the Seacoast Test Facility (STF-1), a proposed Ocean Thermal Energy Conversion (OTEC) project in Hawaii. The assessment, required by the National Environmental Policy Act of 1969, has concluded that the proposed action will not significantly affect the quality of the environment.

As a result of this review, DOE has determined that an Environmental Impact Statement will not be required.

The proposed STF-1 facility will be located on 17 acres of currently unused lava flow at the Natural Energy Laboratory of Hawaii, a State-established center at Keahole Point on the west coast of the Island of Hawaii. It is designed as a land-based facility where biofouling and corrosion experiments on hardware designed for OTEC power systems will be conducted using seawater.

The second stage of the project, which will occur later, will involve a substantial increase in the scope of the experimental program and require a separate environmental review.

The environmental assessment has concluded that the impacts and adverse effects anticipated with the construction and operation of STF-1 include:

- Approximately 17 acres of currently unused lava flow will be excluded from other land uses.

- Minor disturbances of the property have already occurred due to certain accessing and construction operations conducted by the State of Hawaii at the site.

- No significant, long-term, adverse impacts are apt to affect surface-water quality; air quality; terrestrial plant and animal life; or archaeological, historical, social, or economic resources in the area.

- Discharge water from the initial operations of STF-1 will be unadulterated by the input water, and discharge should not have any effect on ocean waters.

- Later experiments in the first stage of STF-1 will involve the addition of small amounts of chlorine to the incoming water. This is not likely to cause any significant adverse impacts.

Single copies of "Environmental Assessment for Stage I of the Seacoast Test Facility" may be obtained from Dr. Lloyd F. Lewis, Program Manager, Division of Ocean Energy Systems, Office of Solar Power Applications, Conservation and Solar Energy, US Department of Energy, Washington DC 20585. Copies are also available for public review in DOE's Freedom of Information Reading Room, 1000 Independence Avenue Southwest, Washington DC 20585; the Chicago Operations and Regional Office, Room A-1136, 175 West Jackson Boulevard, Chicago, Illinois 60604; the Department of Energy, Region IX, 333 Market

Street, 7th Floor, San Francisco, California 94105; the Kailua-Kona Library, 75-140 Hualalai Road, Kailua-Kona, Hawaii 96740; the Natural Energy Laboratory of Hawaii site on Keahole Point, Hawaii 96740; the MASEC Center Library, Mid America Solar Energy Complex, Alpha Business Center, 8140 26th Avenue South, Minneapolis, Minnesota 55420; the Solar Energy Information Center, Solar Energy Research Institute, 61 Perimeter Park, Atlanta, Georgia 30341; the Library of the Western Solar Utilization Network, 715 Southwest Morrison, Suite 800, Portland, Oregon 97205; and the Government and Public Affairs Office of the Northeast Solar Energy Center, 470 Atlantic Avenue, Boston, Massachusetts 02110.

## RECENT PATENTS ISSUED

**Number 4,228,360: Wave Motion Apparatus** to Pablo Navarro, 2110 Magnolia Avenue, Sanford, Florida 32771. 9 claims.

**Number 4,231,312: Flexible Ocean Upwelling Pipe** to Abraham Person, Los Alamitos, California, assignor to Global Marine Incorporated, Los Angeles, California. 19 claims.

**Number 4,233,813: Ocean Thermal Engine** to Walter J. Simmons, Martinsburg, West Virginia, assignor to the University of Delaware, Newark, Delaware. 4 claims.

**Number 4,234,269: Deployment, Release, and Recovery of Ocean Riser Pipes** to Abraham Person, Los Alamitos; Sherman B. Wetmore, Westminster; and James F. McNary, Santa Ana, all of California, assignors to Global Marine Incorporated, Los Angeles, California. 29 claims.

## MORE ON OUR NOVEMBER COVER PHOTO

While our cover photo of the Conoco tension-leg platform (see the November issue of OE) was captioned as opening "up to 6,000-foot depths" and thus likely to influence the design of future OTEC plants, some clarification is necessary.

The actual construction in the North Sea's Hutton Field will be 485 feet. However Mr. L. B. Curtis, Manager of Production Engineering Services for Conoco, says that with tension-leg platforms "we should be able to produce oil and gas in 2,000 feet of water and probably deeper".

When asked what the maximum depths might be for this new offshore construction technology, Curtis said: "Once we pass 2,000 feet, there are several problems to be solved. But the experience we gain with the Hutton Field installation and our ongoing engineering and testing programs should enable us to reach the 6,000-foot depth contour."

The Hutton Field platform is scheduled to be in operation in 1984. (A thorough report on tension-leg platforms and their potential can be found in the February 1980 issue of *Ocean Industry*.)

## US VIRGIN ISLANDS PRIME OTEC SITE

(continued from Page 1)

the average cost of water to the VI Government of \$7.79 per thousand gallons for the years 1976 through 1978. Current costs are well over \$8 per thousand gallons.

The territorial legislature sets consumers' water prices, well below incurred costs. The Westinghouse study stated that "the cost of producing water in the Virgin Islands far exceeds that found anywhere else (in the US) during the period covered by this study".

**PROXIMITY OF COLD-WATER RESOURCE:** Of the Virgin Islands sites, St. Croix was selected as most ideal since it is by far the closest to the deep-ocean cold-water resource. Within only three nautical miles, depths of 1,000 meters (3,000 feet) can be found.

**ADDITIONAL FACTORS:** St. Croix currently has an industrial base (detailed elsewhere in this issue) of significant size for a tropical island, as well as adequate relatively flat and undeveloped land.



Dr. Frank R. Prince, Director of the Virgin Islands Energy Office, addresses the St. Croix OTEC WORKSHOP.

Thus, the separate but parallel efforts of Nord-Aqua and Westinghouse/MARAD result in St. Croix's being considered one of the most likely sites for the world's first commercially-sound OTEC plant. This is based largely on the high cost of both power and fresh water in the area in addition to the ideal physical resources present.

### Mariculture Development

St. Croix has been recognized by long-term OTEC-watchers as the site of extensive mariculture/artificial-upwelling experiments performed under the direction of Dr. Oswald A. Roels through the facilities of the University of Texas Marine Science Institute. Dr. Roels provided an updated presentation of the status of OTEC-related mariculture at the Workshop.

Furthermore, both Dr. Bo Broms of Nord-Aqua, Stockholm, Sweden, and Dr.

### Unplugged Water Heaters

*Our island is beautiful and we think it is a great place to live—but it is different. We don't always have the services and conveniences you are accustomed to. Our power plant (WAPA) is run-down and inadequate; often the power goes off unexpectedly, and sometimes power is rotated during maintenance operations. Our water supply is scarce; we ask that you help in conserving it. Your water heater may be unplugged to save power—just plug it in.*

These excerpts from a notice found in all rooms of the Gentle Winds Beach Resort, site of the OTEC WORKSHOP, summarize concisely the water and power situation existing today in St. Croix.

Henry W. Moeller of the Hydro-Botanical Company, South Hampton, New York, told the conferees of both the potential and the success of current mariculture experiments. Moeller's work indicated production of seaweed and biomass production far in excess of the annual production by weight of the most fertile land under agricultural production *anywhere*.

While the scope of this publication is necessarily limited, suffice it to say that efforts at commercial development are under way by private mariculture interests, as is the investigation of joint efforts with various consortiums which will bid on the Pilot Plant PON. Interested readers are invited to contact the editor of OE for further mariculture information.

### Island Energy Problems

Dr. Frank Prince, Director of VIEO, reiterated the problem of most of the Caribbean Islands in that all energy must be imported by ship, resulting in electric power costs two to three times the national average, with current costs in St. Croix of about 17¢ per kilowatt hour. The example was provided of a popular local resort hotel spending over \$20 per room per day to provide the amenities of heated fresh water and air conditioning for its guests. Prince pointed out that it was the desire of the Virgin Islands Government to encourage OTEC development, but "at zero risk to the Government".

### The Highest Priority

The highest ranking representative of the Virgin Islands Government in attendance at the meeting was Commissioner Adamdeo D. Francis of the Department of Commerce, who pointed out that "power and water have the highest priority" of Governor Juan Luis, as they not only directly affect the Islands' economy, but also indirectly affect both crime and education. Francis pointed out that the actual cost of fresh water was closer to \$16 per thousand gallons, since only about 50% is deliverable due to leakage in the distribution system

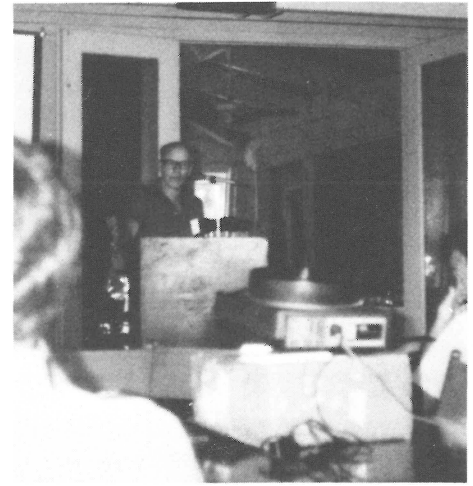

Dr. Bo Broms of Stockholm, consultant to the Nord-Aqua Group, in discussion with Workshop attendees.

and illegal tapping. Repeated loss of new business in the Virgin Islands ventures was due to poor water and power. (Currently established industries often have their own water and power systems, as well as direct telephone lines to the mainland.)

### No Nirvana for OTEC

While the high cost of power and water, plus inherent OTEC resources, indicate great potential for OTEC facilities, other problems exist in the Virgin Islands. The fact that at any one time only a third of the installed conventional power-generation capacity is operable points to chronically poor maintenance. Yet importing technicians to maintain and operate potential OTEC plants flies in the face of the Government's desire to train local person-

(continued on Page 4)

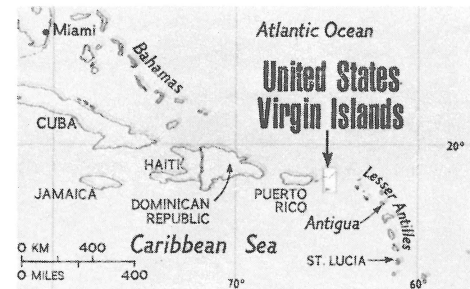

### A RECOMMENDED REFERENCE

OTEC planners are referred to the February 1981 issue of National Geographic, which includes two articles as excellent reference materials: "Paradise Comes of Age: The US Virgin Islands" and "The Seething Caribbean". The latter deals extensively with the changing political aspects of the area.

In addition, that issue contains an excellent double map of the West Indies and Central America, including multiple potential OTEC sites. The map can be purchased separately from Cartographic Division, National Geographic, Washington DC 20036.



**Combined OTEC/Desalination  
Plant Proposed at December  
OTEC Conference**

(continued from Page 3)

nel to do so. Better education for their children and future jobs are growing concerns of Virgin Islands parents.

Endemic joblessness exists, with the contrast between tourists' lifestyles and native poverty encouraging strife.

**Governor's Council Formed**

At the Workshop's close, the attendees were decidedly enthusiastic regarding the potential of OTEC in St. Croix. Patrick E. Slattery, representing Ebasco Services Incorporated of New York City, suggested the formation of a committee to pursue the obvious optimism.

In recognition of the Workshop's success, Governor Luis announced in his letter of November 17th to the Workshop's participants that a group known as the *Governor's Advisory Council on Marine Affairs* had been established, with Dr. Prince as Chairman. Initial members of the Council are Mr. Tom Blake, Water and Power Authority (WAPA); Dr. J. R. Maxfield, Florida Institute of Technology; Mr. Brian Coffay, Westinghouse; and Dr. Bo Broms, Swedish OTEC-Nord-Aqua Group, with the initial meeting scheduled for December.

Since that time, a consortium has been formed to possibly bid on the DOE-sponsored Program Opportunity Notice (PON) for an OTEC pilot plant with St. Croix as the site.

Further details on this and other industry-wide bids on that PON will appear in our January issue.



**NAMES IN THE NEWS**

**Dr. Oswald A. Roels**, formerly of the University of Texas Marine Science Institute, is now President of Worldwide Protein Incorporated, a firm involved in the development of mariculture, desalination, and OTEC power, at 457 Robert Drive, Corpus Christi, Texas, (512) 851-2701.

**Mr. Jay E. Yaffo**, formerly of Alfa Laval Incorporated, is now Managing Director of the Ocean Thermal Corporation, a division of Basic Resources, Incorporated, developers of OTEC commercialization, at 595 Madison Avenue, New York, New York 10022, (212) 758-1990.

**Dr. Leonardo Perez y Perez**, formerly of the Puerto Rico Electric Power Authority, is now Co-ordinator for Ocean Engineering of the Department of Mechanical Engineering of California State University, Long Beach, California 90840, (213) 498-4407.

**Malcolm S. Jones Jr.**, formerly of the Reynolds Metals Company, is now with Ebasco Industries, 130 Newport Beach Drive, Newport Beach, California 92660, (714) 759-7217.

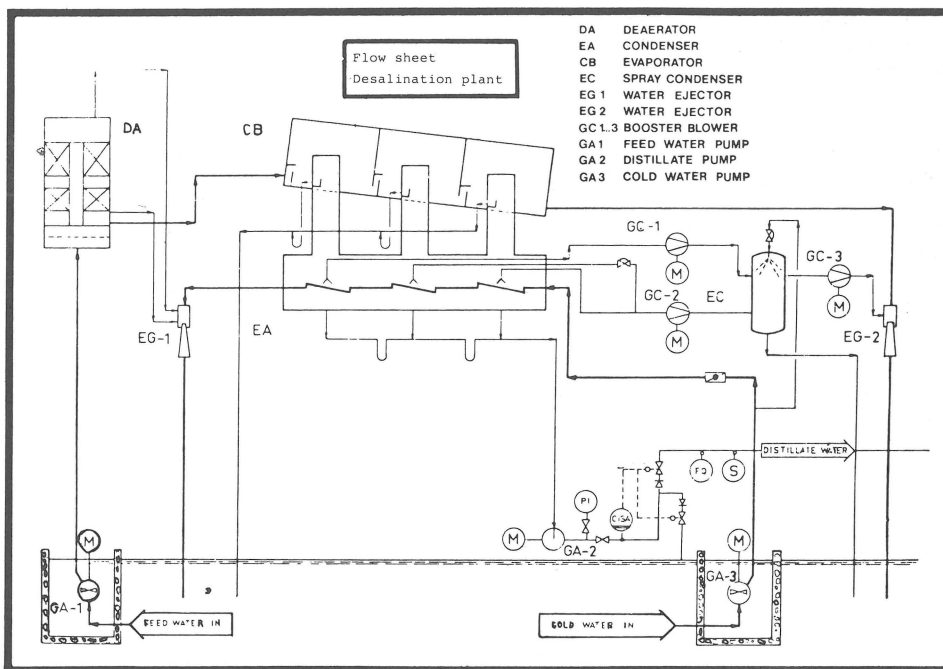

**POWER GENERATION AND DESALINATION BASED ON OCEAN THERMAL ENERGY BY THE SWEDISH OTEC-NORD-AQUA GROUP**

Data on the Nord Aqua process:

Cold water:	Temperature at intake	11	$^{\circ}\text{C}$
	Flow rate	1.8	$\text{m}^3/\text{s}$
Warm water:	Temperature at intake	27	$^{\circ}\text{C}$
	Flow rate	1.8	$\text{m}^3/\text{s}$
	Fresh water production, six modules	3 400	$\text{m}^3/\text{d}$
	Total power requirement	0.525	MW

Data on the OTEC power cycle:

	Electric output, gross	0.86	MW
	Electric output, net	0.6	MW
Cold water:	Temperature at intake	6	$^{\circ}\text{C}$
	Flow rate	1.8	$\text{m}^3/\text{s}$
Warm water:	Temperature at intake	27	$^{\circ}\text{C}$
	Flow rate	3.6	$\text{m}^3/\text{s}$

**THE VIRGIN ISLANDS ECONOMY**

With a total population of 100,000 the three US Virgin Islands (St. Thomas, St. John, and St. Croix) have the highest per-capita income of any island in the West Indies—over \$5,000 a year. Of the 41,000 employed, 12,000 work in the tourist industry.

Other industry is dominated by the Armada Hess oil refinery, one of the largest in the world, and Martin Marietta's alumina processing plant, both on St. Croix. These two firms have enjoyed 90% subsidies on income tax and duties, though Armada Hess's exemptions are about to expire. Currently its Chairman, Leon Hess, is threatening to move elsewhere unless Governor Luis extends the firm's financial incentives. While the generous tax exemptions irritate islanders, both firms pump millions into the local economy through wages, scholarships, and donations.

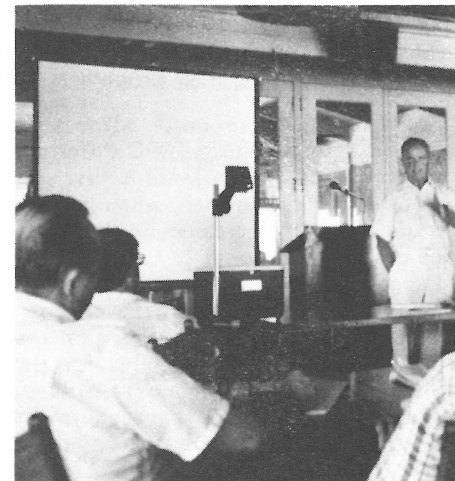

Dr. Oswald Roels (standing), President of Worldwide Protein Incorporated, responds to a question by Dr. Robert Fulton (seated left), Manager of the Washington DC office of Gibbs and Cox Incorporated.

## SWEDISH NORD-AQUA GROUP PROMOTES OTEC-BASED POWER GENERATION AND DESALINIZATION

The OTEC WORKSHOP held in St. Croix in November was dominated by discussion of a combined OTEC-Desalination Plant proposed for sites such as St. Croix, US Virgin Islands, by the Swedish OTEC-Nord-Aqua Group. The member firms of Nord-Aqua are Alfa-Laval and SWECO, both of Stockholm, Sweden, and Ra-Shipping of Parainen, Finland.

The Group's representatives stated that, using state-of-the-art technology, such a system would involve a land-based OTEC plant in the range of 0.5 to 1.0 MW in combination with a Nord-Aqua desalination plant with a capacity of about one million gallons of fresh water per day—*with no fuel costs!* The system could also be designed to deliver both fresh water and electricity.

The desalination system utilizes existing temperature differences in seawater to drive a distillation process not involving heating. The only energy needed to keep the process going is electricity for the pumping of water. Nord-Aqua claims that a temperature difference of 10°C is sufficient for desalination, and that a test unit operated on as little as 7°C from an experiment using the cooling water discharge from a coal-fired power plant.

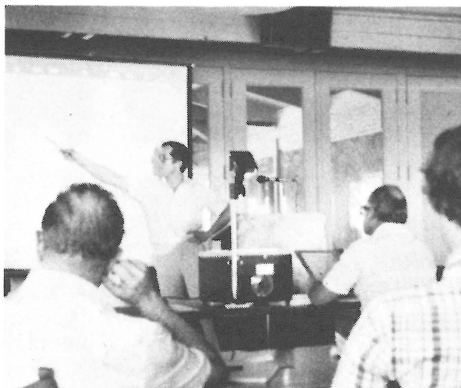

**Bengt Lindqvist, OTEC Project Manager of Ra-Shipping of Finland, part of the Nord-Aqua Group, detailing their proposal.**

The Nord-Aqua proposal advocates a combined system with a 20°C difference in which the cold deep water is first used in an OTEC unit, and then, when its temperature has been increased, in the Nord-Aqua desalination unit.

Bengt Lindqvist of Ra-Shipping explained that "standard Alfa-Laval cross-flow OTEC plate heat exchangers" of stainless steel would be suitable for this application, with "every component based on known technology". Using a one-meter cold-water pipe, six modules, each with the capacity for handling 500 cubic meters per day, would be situated on a 25-square-meter deck. A 20°C delta-T before the OTEC cycle was estimated to be reduced to 17°C afterward, and to be more than ample for the Nord-Aqua desalination process.

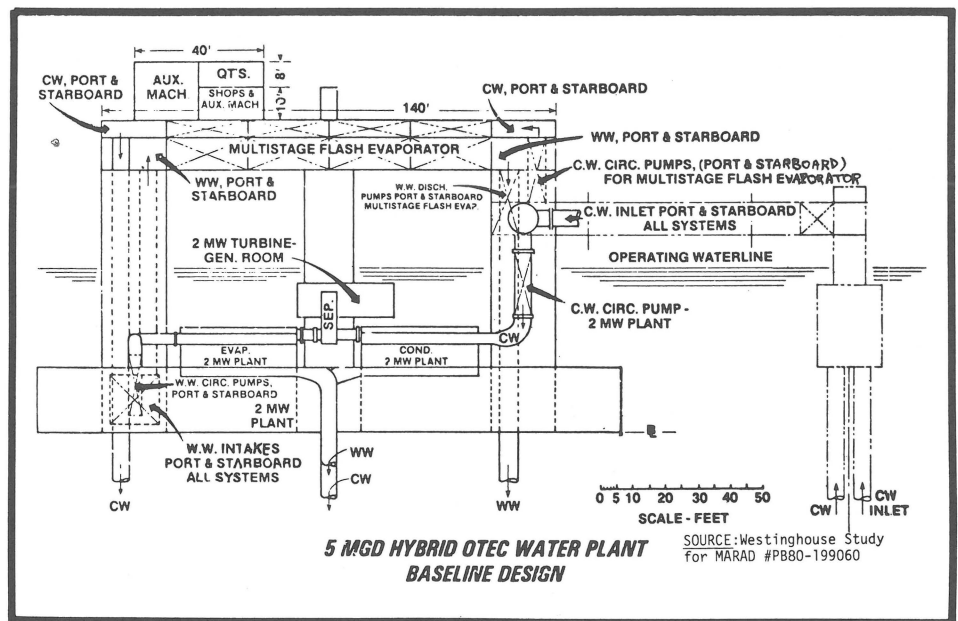

Bengt added that low maintenance costs were expected, and that the costs would be "competitive".

A combination of anti-fouling measures was detailed, including both chlorination and cleaning-in-place procedures.

The OTEC-Nord-Aqua plant was designed for St. Croix on a reef about 400 meters offshore with a water depth of about 20 meters, using a 1,250-meter-long cold-water pipe. The plant is designed as a concrete caisson, with the OTEC power system accommodated inside the caisson and the Nord-Aqua modules atop the caisson's deck. The cold-water pipe would go down 800 meters and be fabricated of high-density polyethylene.

The Nord-Aqua Desalination Plant uses the vacuum-distillation process in a three-stage evaporator, as outlined in the accompanying illustration.

### SECOND DEPLOYMENT OF MINI-OTEC WOULD INCLUDE MARICULTURE TESTS

While plans for a second deployment of Mini-OTEC remain tentative, the University of Hawaii's Department of Oceanography has firmed up plans for mariculture testing using discharge water from the system.

Cold water brought up from depths of 1,000 meters is to be used to grow algae as food for larger creatures such as salmon, as well as to supply nutrients for the plant species popularly called "nori", the seaweed used in Japanese food such as sushi.

Six to eight tanks will be placed on the deck of Mini-OTEC to receive sunlight for algae growth, while below decks silver salmon will be cultured in tanks with temperatures of 10° to 13° Centigrade.

### US GOVERNMENT PROCUREMENT INVITATIONS AND CONTRACT AWARDS

Listed below are procurement invitations and contract awards related to OTEC in particular and ocean resources in general culled from the *Commerce Business Daily*. This is not to be construed, however, as a complete list.

● **Nov 10: Assess the Availability of Titanium and Its Current and Future Needs:** Grant EMW-G-0008, \$91,000, awarded on a sole-source basis to the National Materials Advisory Board of the National Academy of Sciences, 2101 Constitution Avenue, Washington DC 20418. Federal Emergency Management Agency, Research and Management Branch, M Street Building, Washington DC 20472.

**Nov 17: Prepare a Comparative Analysis of Alternative Energy Policy, Including Definition of Current Schools of Thought About the Future Direction of US Energy Policy and Comparison of Various Policy Alternatives:** Contract 133-0410.0, October 1st, 1980, for \$33,785, awarded to Robert L. Olson, Arlington, Virginia. Office of Technology Assessment, US Congress, Washington DC 20610.

**Nov 19: Feasibility Study: Installation of a Wind Turbine Generator, Ascension Island, South Atlantic Ocean:** Work consists of furnishing architect-engineering services including research into the state of the art, site selection, quantity and size of units best suited for the particular application, noise and RF interference problems, estimated cost, economic analysis, and potential for funding under the "Wind Energy Systems Act of 1980". This will be a firm fixed-price AE contract with an estimated starting date in January 1981 and completion date in March 1981. Responses must be received within 21 calendar days of this notice and must include a Form SF 254 and SF 255 if one has not been submitted to this office within the past

year. Firms desiring consideration shall submit data as described in Note 62. This is not a request for proposal. Eastern Space and Missile Center (AFSC), Contracts Division/PMPC Patrick Air Force Base, Florida 32925, Attn: A. D. Jones, 305/494-7091.

**Nov 19: Continued Research on Atlantic Oceanography:** Contract N00014-79-C-0072, October 31st, 1980, for \$2,261,305, awarded to Woods Hole Oceanographic Institution, Woods Hole, Massachusetts 02543. Office of Naval Research, 800 North Quincy Street, Arlington, Virginia 22217.

**Nov 20: Ocean Current Meter Analysis Study:** Negotiations are being conducted with Science Applications Incorporated, 1710 Goodrich Drive, McLean, Virginia 22102. Office of Naval Research, 800 North Quincy Street, Arlington, Virginia 22217.

**Nov 25: "Aquahol"—A Developmental Project:** Contract FG-01-81-AF-20001, for \$384,324, awarded to Palm Beach Junior College Foundation Incorporated, 4200 Congress Avenue, Lake Worth, Florida 33461. Department of Energy, Office of Procurement Operations, Washington DC 20585.

● **Nov 26: Wave Current Interactions and Wave Energy Extraction:** Contract N00014-80-C-0531, November 7th, 1980, for \$131,000, awarded to Massachusetts Institute of Technology, 77 Massachusetts Avenue, Room E19-702, Cambridge, Massachusetts 02139. Office of Naval Research, 800 North Quincy Street, Arlington, Virginia 22217.

**Dec 1: Undersea Cable Analysis to Investigate and Report on Mechanical Design of Undersea Cables Summarizing Procedures Which Can Be Used for Designing the Mechanical Portion of a Cable:** Contract N66001-81-R-0137. Negotiations are being conducted on a sole-source basis with Knapp Engineering Incorporated, 98-1033 Kupukupu Place, Aiea, Hawaii 96701 because of this company's unique combination of technical expertise. Commander, Naval Ocean Systems Center, San Diego, California 92152, Attn. L. James, Code 4222, (714) 225-2756.

**Dec 1: Analysis of Design Procedures for Mechanical Portion of Undersea Cable:** RFP N66001-81-R-0138. Negotiations are being conducted on a sole-source basis with Philip T. Gibson Consulting, 12001 Montecito Road, Los Alamitos, California 90720 because of this company's unique combination of technical expertise and experience in testing and analysis to predict cable failure and retirement criteria. Commander, Naval Ocean Systems Center, San Diego, California 92152, Attn. L. James, Code 4222, (714) 225-2756.

**Dec 1: Analysis of Undersea Cable on Methodology to Be Used to Determine Important Aspects to Be Considered in Selection or Design:** RFP N66001-81-R-0136. Negotiations are to be conducted on a sole-source basis with Cable Technology Incorporated, 3511 Center Drive Southwest, Roanoke, Virginia 24108, because of this company's unique qualifications in research and development of undersea cable technology. Commander, Naval Ocean Systems Center, San Diego, California 92152, Attn. L. James, Code 4222, (714) 225-2756.

**Dec 1: Repair of Government-Owned Pumps, Turbines, Motors, and Pump Governors (which were originally manufactured by the firm named below) in accordance with specifications of BOA N00024-81-G-4136:** Negotiations are being conducted with Westinghouse Electric Com-

pany, Marine Division, Sunnyvale, California 94088, as this firm has the facilities, experience, personnel, and proprietary data to repair this equipment. All orders placed under this agreement shall be issued by the Administrative Contracting Office, DCA-SPRO, Westinghouse, Sunnyvale. See Notes 40, 46, and 73.

**Dec 4: Assessment Management System for Energy Technology Based Program:** Negotiations are being conducted with R&D Associates, Marina Del Ray, California 90291, for Solicitation AC-01-80-ER-30005. Department of Energy, Office of Procurement Operations, Washington DC 20585, (202) 376-9290.

**Dec 4: Development of a Parametric Cost Analysis System for Advanced Energy Systems With a Two-Year Support-Service Requirement:** Solicitation RFP RP01-81-CR-10010. Department of Energy, Office of Procurement Operations, Washington DC 20585, (302) 376-9290.

**Dec 5: Research on Solar Activity:** Contract N00014-81-C-0065, November 12th, 1980, for \$126,190, awarded to the Carnegie Institution of Washington, 1530 P Steet Northwest, Washington DC 20005. Office of Naval Research, 800 North Quincy Street, Arlington, Virginia 22217.

**Dec 9: Continued Analytical Wave Motion Study:** Negotiations are being conducted with Gould Incorporated, Chesapeake Instrument Division, 6711 Bay Meadow Drive, Glen Burnie, Maryland 21061. Office of Naval Research, 800 North Quincy Street, Arlington, Virginia 22217.