

2015

## Mapping the Hidden: An Interpretative Phenomenological Analysis of Multigenerational Family Secrets

Tracy Oliver

Nova Southeastern University, drtracyoliver@gmail.com

Follow this and additional works at: [https://nsuworks.nova.edu/shss\\_dft\\_etd](https://nsuworks.nova.edu/shss_dft_etd)



Part of the Counseling Commons, Counseling Psychology Commons, Family, Life Course, and Society Commons, and the Quantitative, Qualitative, Comparative, and Historical Methodologies Commons

### Share Feedback About This Item

---

#### NSUWorks Citation

Tracy Oliver. 2015. *Mapping the Hidden: An Interpretative Phenomenological Analysis of Multigenerational Family Secrets*. Doctoral dissertation. Nova Southeastern University. Retrieved from NSUWorks, College of Arts, Humanities and Social Sciences – Department of Family Therapy. (11) [https://nsuworks.nova.edu/shss\\_dft\\_etd/11](https://nsuworks.nova.edu/shss_dft_etd/11).

This Dissertation is brought to you by the CAHSS Theses, Dissertations, and Applied Clinical Projects at NSUWorks. It has been accepted for inclusion in Department of Family Therapy Dissertations and Applied Clinical Projects by an authorized administrator of NSUWorks. For more information, please contact [nsuworks@nova.edu](mailto:nsuworks@nova.edu).

**Nova Southeastern University  
Graduate School of Humanities and Social Sciences**

This dissertation was submitted by Tracy Oliver under the direction of the chair of the dissertation committee listed below. It was submitted to the Graduate School of Humanities and Social Sciences and approved in partial fulfillment of the requirements for the degree of Philosophy in the Department of Family Therapy at Nova Southeastern University.

Approved:

5/12/15  
Date of Proposal

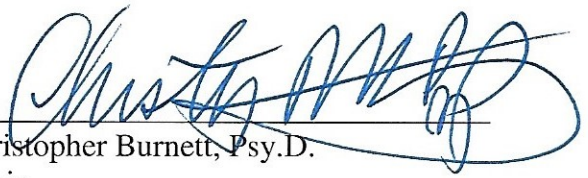
  
Christopher Burnett, Psy.D.  
Chair

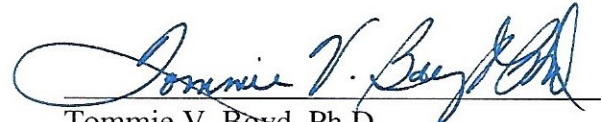
  
Tommie V. Boyd, Ph.D.  
Committee

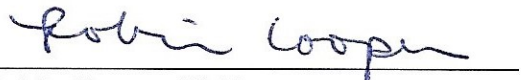
  
Robin Cooper, Ph.D.  
Committee

6/10/15  
Date of Final Approval

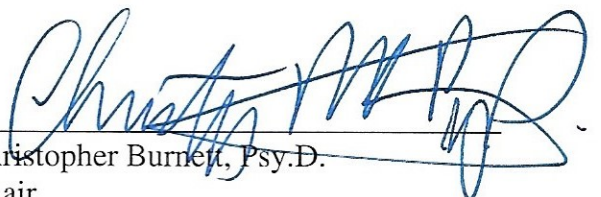
  
Christopher Burnett, Psy.D.  
Chair

Mapping the Hidden:

An Interpretative Phenomenological Analysis of Multigenerational Family Secrets

by

Tracy Oliver

A Dissertation Defense Presented to the

Graduate School of Humanities and Social Sciences of Nova Southeastern University

In Partial Fulfillment of the Requirements for the Degree of

Doctor of Philosophy

**Nova Southeastern University**

**2015**

Copyright

by

Tracy Oliver

May 2015

## **Acknowledgments**

I would like to acknowledge my parents, Vilfranc and Elsie Saintelus, for all of their hard work and dedication to me, my education, and my success. My brothers Paul and Billy are my first friends and confidants. As the big sister and secret keeper, they are and always have been a source of motivation to accomplish my goals. An extension of gratitude also goes to my mother-in-love, Gilda Oliver, and my mother for the many days they've watched their grandson in order to allow me to complete my degree.

I would also like to thank my wonderful husband, Carime Oliver, for his encouragement and cheering during those moments when I just wanted to give up. Outside of my immediate family, he has been the greatest supporter of my pursuit in higher education. He is my best friend. His calm personality and sense of humor have been a great relief throughout this process.

During the past seven years I have received support and encouragement from a number of individuals. I would like to thank my dissertation committee, Tommie V. Boyd, Ph.D. and Robin Cooper, Ph.D. I especially want to thank my chair, Chris Burnett, Psy.D., who has been present over the past four years as this project grew from an idea, morphed into something else altogether, and is now completed. I am thankful for his time and the many hours he spent with me in shaping my ideas of family secrets and the functions they serve. I would also like to thank Charmaine Borda, Ph.D. who has filled several roles including teacher, supervisor, and friend.

I also thank my friends and classmates. There are countless who have leant an ear, shared wisdom, and encouraged me by their faith. These relationships have enriched my life, both academically and personally.

A great thanks goes to the participants of this study. They have shared their family secrets and their experiences. The majority shared information that they hadn't ever shared with others which is a testament to their willingness to participate. This study would not be complete without the authenticity of their unique experiences.

Finally, none of this would have been possible apart from the grace of God. He has sustained me throughout this journey. To Him be all the glory and praise.

*Jesus looked at them and said,*

*“With man this is impossible, but with God all things are possible.”*

– Matthew 19:26

## TABLE OF CONTENTS

Acknowledgments.....	IV
Table of Contents .....	VI
List of Tables .....	XI
List of Figures.....	XII
Abstract.....	XIII
CHAPTER I: INTRODUCTION.....	1
What's in a Secret? .....	1
Types of Secrets.....	2
Secrecy versus Privacy .....	4
Family Secrets.....	5
Family Systems.....	6
Bowen Family Systems Theory .....	7
The emotional system.. .....	8
Mapping family secrets.....	9
Purpose of Study.....	10
CHAPTER II: REVIEW OF THE LITERATURE .....	12
Family as a System .....	14
Bowen Family Systems Theory .....	15
Family as an Emotional System.....	17
Anxiety and Differentiation .....	19

Anxiety.....	19
Differentiation.....	21
Triangles .....	24
Multigenerational Transmission Process .....	29
Function of Family Secrets .....	31
Summary.....	31
 CHAPTER III: METHODOLOGY .....	 33
Phenomenological Research .....	33
Interpretative Phenomenological Analysis (IPA).....	34
Participant Selection .....	35
Design and Procedure .....	36
Data Collection .....	37
Semi-structured interview.....	37
The interview schedule.....	38
Recording.....	39
Data Analysis .....	39
Initial noting.....	39
Identifying themes .....	40
Making connections.....	40
Writing the analysis .....	41
Ethical Considerations .....	42
 CHAPTER IV: RESEARCH FINDINGS .....	 44
Analysis.....	46



Step 1: Reading and Re-reading .....	46
Step 2: Initial Noting.....	46
Step 3: Developing Emergent Themes .....	48
Step 4: Searching for Connections across Emergent Themes .....	49
Step 5: Moving to the Next Case .....	50
Step 6: Looking for Patterns across Cases .....	50
What's In a Secret? .....	51
Keep it to yourself.....	51
Living with a Secret .....	52
Island mentality.....	52
Faith and community .....	54
Emotional effects .....	56
Finding Meaning.....	58
What it means to me. ....	58
Anxiety and Differentiation .....	59
Burden of secret keeper .....	60
Cutoffs and estrangements.....	62
Forming triangles .....	63
Multigenerational Transmission Process .....	67
Generation to generation.....	68
Functions of Family Secrets.....	69
Secrets as a means of protection. ....	69
Incorporating the Genogram .....	70

Sam .....	71
Brad .....	72
Rebecca .....	72
Ron .....	73
Fay .....	74
Summary .....	76
CHAPTER V: DISCUSSION AND IMPLICATIONS OF THE STUDY .....	79
Strengths and Limitations .....	80
Self of the Researcher .....	81
Bracketing .....	82
Ethical Considerations .....	85
Implications .....	86
Future Research .....	86
For Marriage and Family Therapy .....	88
For Clinicians .....	89
Concluding Thoughts .....	89
References .....	91
Appendices .....	95
Appendix A: Mental Health Professional and Clergy Member Invitation .....	96
Appendix B: Adult/General Informed Consent .....	97
Appendix C: Interview Schedule: Participant’s Genogram and Experience of Family Secret .....	100

Appendix D: Revised Interview Schedule: Participant’s Genogram and Experience of Family Secret.....	102
Appendix E: Individual Superordinate Themes.....	104
Appendix F: Participant Genograms.....	116
Sam’s Genogram.....	116
Brad’s Genogram .....	117
Rebecca’s Genogram .....	118
Ron’s Genogram .....	119
Fay’s Genogram.....	120
Biographical Sketch .....	121

## **List of Tables**

Table 1: Participant Information.....	45
Table 2: Initial Comments.....	47
Table 3: Emergent Themes.....	48
Table 4: Superordinate Themes.....	50
Table 5: Master Themes.....	51
Table 6: Recurrent Themes.....	77

## List of Figures

Figure 1: Triangulation.....	63
Figure 2: Ron’s triangle 1.....	65
Figure 3: Ron’s triangle 2.....	66
Figure 4: Fay’s triangle.....	67
Figure 5: Sam’s family secrets.....,	71
Figure 6: Brad’s family secrets.....	72
Figure 7: Rebeca’s family secrets.....	73
Figure 8: Ron’s family secrets.....	74
Figure 9: Sam’s family secrets.....	75
Figure 10: Sample Selection of multigenerational family interviews.....	86

## **Abstract**

Family secrets can be a driving force, whether explicitly or implicitly, for many seeking therapy. Despite this, there is little qualitative research examining how individuals experience and make sense of their family secrets. Through this study the researcher examined the phenomenon of family secrets amongst five individuals from different families. Qualitative research using Interpretative Phenomenological Analysis (IPA) along with a Bowen Family Systems Theory approach was used to explore multigenerational family secrets. Purposive sampling was used to select that participants and data was collected through semi-structured interviews. A genogram was also drafted to identify multigenerational relationships and the history of family secrets.

By exploring and mapping the functions of multigenerational family secrets, the researcher examined in detail how participants make sense of their lived experience with holding a family secret. Through semi-structured interviews, the researcher was able to extract the meanings found within keeping a secret and the functions that secrets serve within families. Six superordinate themes were identified: what's in a secret, living with a secret, finding meaning, anxiety and differentiation, multigenerational transmission process, and functions of family secrets. The data collected and analysis reflecting the experiences shared by the five participants add to the existing literature on the phenomenon of keeping family secrets and details the implications for the emotional system and marriage and family therapy. By mapping the hidden, a new conversation on the taboos of family secrets can lead to new hope for individuals and generations to come.

## CHAPTER I: INTRODUCTION

*Everyone has a secret.* As I reflected on a previous class assignment that required drafting my own genogram, I asked my husband why he had been worried about me interviewing his parents. He proceeded to share about a family secret and the shame that lingered as a result. My husband then asked me about my family secrets, to which I replied, I don't have any. He matter-of-factly retorted, "Everyone has a secret." This led to a discussion about the definition of secret, who is involved in the secret, and how the secret affects generation after generation.

### What's in a Secret?

When I began to explore secrets, I had so many questions. What is a secret? Who defines what a secret is? Does that definition change depending on what or who the secret is about or regarding?

By definition (Merriam-Webster), a *secret* is something kept hidden or from the knowledge of others. Its origin is from the Latin *secretus*, which is from the past participle of *secernere* meaning to separate or distinguish from. Broken down, *se-* means apart and *cernere* is to sift. Secrets, according to Karpel (1980), "involve information that is either withheld or differentially shared between or among people" (p. 295).

Bok (1983) explains that what distinguishes a secret is the intention. Keeping secrets involve a conscious decision to withhold information (Vangelisti, 1994). To keep a secret from someone, as Bok further explains, "is to block information about it or evidence of it reaching that person, and to do so intentionally" (p. 5). This includes the secret itself and the effort behind maintaining the secret (secrecy), such as avoiding the topic or certain people that may be involved in the secret.

## Types of Secrets

Secrets can be differentiated by purpose, duration, and outcome (Imber-Black, 1998). Imber-Black describes four types of secrets. *Sweet secrets* can be innocent and harmless. Imber-Black explains that such secrets “often enable a new and positive view of a person or a relationship” (p. 13). They usually include a surprise party planned in secret or a pending wedding proposal.

*Essential secrets* are important and can be a sign of individual and relational growth. These secrets “promote necessary boundaries that define a relationship” (Imber-Black, 1998, p. 14). An example would be sharing banking information, a traumatic or embarrassing experience, etc. Imber-Black (1998) distinguishes between sweet and essential secrets as, “In contrast to sweet secrets, which are temporary and are created to benefit another person, essential secrets are long-lasting and are made to enhance the development of self, relationships, and communities” (p. 15).

*Toxic secrets* are just that—toxic. These secrets are often negative and can be lethal. Imber-Black (1998) explains that these secrets “poison our relationships with each other” (p. 15). Imber-Black describes that, “These are the secrets that take a powerful toll on relationships, disorient our identity, and disable our lives. They handicap our capacity to make clear choices, use resources effectively, and participate in authentic relationships” (p. 15). Holding toxic secrets often has negative effects on emotional well-being. For example, a woman overly concerned about her husband discovering an abortion she had before she met him and the resulting fear surrounding the secret being revealed.



*Dangerous secrets* put people in immediate danger, emotionally or physically (Imber-Black, 1998). These secrets include abuse of minors, domestic violence, and harm to self or others. These secrets can also interfere with emotional wellbeing, thus causing anxiety and introducing shame. Imber-Black (1998) distinguishes between toxic and dangerous secrets as, “In contrast to toxic secrets, which allow time to carefully consider the impact of continued secrecy or openness on a network of relationships, dangerous secrets often require swift and immediate action to safeguard life” (p. 18).

Secrets can also be defined based by their subject matter, such as taboo topics, rule violations, and conventional secrets (Vangelisti, Caughlin, & Timmerman, 2001). *Taboo topics* are “activities that are stigmatized by one’s family or by society” (p. 13). These can include abuse, divorce, sexual preference, and mental health. *Rule violations* are “secrets about breaking norms of conduct common to many families” (p. 13). These can include cohabitation, as well as sexual and criminal activity. *Conventional secrets* are often considered inappropriate for discussion. These can include religion, salary, physical health problems, and death.

As Bok (1983) plainly states, “Anything can be kept a secret so long as it is kept intentionally hidden, set apart from its keeper as requiring concealment” (p. 5). But what distinguishes a secret from private information? Secrets are socially constructed and therefore “the definitions of secrecy and privacy can change by what a given culture stigmatizes or values” (Imber-Black, 1993, p. 15). As it pertains to family secrets, “every family makes its own rules about what is secret and what is private” (Imber-Black, 1998, p. 20).

### Secrecy versus Privacy

There is a fine line between secrecy and privacy (Papp, 1993). The same thing that is private for one person may be a secret for someone else. This can be influenced by cultural values and personal judgment (Papp). Imber-Black (1998) explains that “secrecy and privacy sometimes coexist in a circular and paradoxical relationship with each other” (p. 20). This is primarily due to different definitions of secrecy and privacy that exist amongst different systems (Imber-Black, 1993).

Bok (1983) defines secrecy as intentional concealment, thus distinguishing it from privacy, which is defined as information that is protected from unwanted access. According to Imber-Black (1998) “Hiding and concealment are central to secret-keeping, but not to privacy” (p. 21). Bok (1983) goes further to distinguish privacy and secrecy by explaining that privacy requires no hiding while “secrecy hides far more than what is private” (p. 11).

In contrast with privacy, secrets held between one generation and over multiple generations can cause adverse effects. Karpel (1980) states that “in the case of secrets as opposed to mere privacy, contrary to the popular cliché, what we don't know does hurt us” (p. 298). Therefore, when making a claim that something is private or a secret, we can consider who the secret is regarding and how it will affect those or others involved directly or indirectly. Imber-Black (1998) distinguishes it as secrecy rather than privacy when withholding information impacts another person's life choices, decision-making capacity, and well-being.

Another characteristic trait of secrets is that they require additional protection (Bok, 1983). This is in part due to the fact that “secrets are often connected to fear and

anxiety regarding disclosure, while privacy implies a certain zone of comfort, free from the unwanted entry of others” (Imber-Black, 1993, p. 19). When information is truly private, it has no bearing on our physical or emotional health (Imber-Black, 1998).

### **Family Secrets**

Secrets are everywhere, but when they are within the family, they can be devastating. Some members may make the claim that something is private, when in fact is not. Papp (1993) explains that “one way to distinguish between secrecy and privacy is to determine the relevance of the information for different family members” (p. 67).

Another way to distinguish secrecy from privacy is by the function the information serves. Depending on the content and whom it affects, Imber-Black (1998) states that “making a claim that something is private may be inappropriately self-serving or appropriately protective” (p. 20). Secrets look different from person to person and the definition can be more complicated when you look from one family to the next. What one person in one family or culture may deem as secret, another member in another family may simply look at as private. As Imber-Black explains, “the definitions of what is secret and what is private change across time, cultures, and sociopolitical circumstances, depending on what a given culture or a particular family stigmatizes and values” (p. 20).

Karpel (1980) defines three types of family secrets based on who is involved in the secret. *Individual secrets* involve one person keeping a secret from the other person or persons in the family. These secrets are kept by an individual member of the family. *Internal family secrets* involve at least two people keeping a secret from at least one other

person. These secrets are kept by some members of the family. *Shared family secrets* involve all members of the family knowing the secret and keeping it from those outside the family. These secrets are kept by the whole family. These secrets are formed based on the boundaries created within the family system.

Other roles with secrets include those:

- 1) who know the secret,
- 2) who don't know the secret, and
- 3) who know the secret but are unaware of others who know.

The *secret-holder* knows and keeps the secret and the person who does not know the secret is *the unaware* (Karpel, 1980). The *subject*, is the person that the secret is about (Karpel, 1980).

Another consideration regarding secrets is location. Location, location, location. Within families, the location of the secret can be critical. Questions that are evoked include where is the secret kept and how does a family decide this? Does the responsibility shift from generation to generation?

When people keep secrets, the assumption is that there is a reason. This conjures other questions. What function does a secret have within a family? How is keeping a secret useful? What is the benefit of holding the secret? Whether it is personal or indirect, there must be an advantage because there is something powerful about holding a secret.

### **Family Systems**

From a systems point of view, there's a functional advantage to keeping a secret from public knowledge. Like magnets, secrets in family relationships can draw some

members close while repelling others (Imber-Black, 1998). They are “relational, shaping dyads, triangles, hidden alliances, splits, cutoffs, defining boundaries of who is ‘in’ and who is ‘out,’ and calibrating closeness and distance in relationships” (Imber-Black, 1993, p. 9). This is why a Bowen Systems Theory approach to analyzing family secrets is fundamental.

### **Bowen Family Systems Theory**

The Bowen Family Systems Theory is the result of Murray Bowen’s work with families and is about human relationship functioning (Bowen, 1978). It is “based on assumptions that the human is a product of evolution and that human behavior is significantly regulated by the same natural processes that regulate the behavior of all other living things” (Kerr & Bowen, 1988, p. 3). The theory is useful in understanding the family emotional system and relationship processes (Bowen, 1978; Kerr & Bowen, 1988; Knauth, 2003). From a natural systems perspective, the Bowen Family Systems Theory helps to better understand human behavior, patterns, and symptom formation as well.

Bowen defined *family* as an emotional and relationship system (Bowen, 1978). The family includes the immediate nuclear family (including parents and siblings) and the extended family (including multigenerational family members). The family environment can also include the larger social systems of which the family is a part of, such as church, school, or work (Bowen, 1978).

The Bowen Family Systems Theory emphasizes how relationship patterns are repeated through the generations and how they can influence behavior and health (Bowen, 1978; Kerr & Bowen, 1988). Bowen Family Systems Theory “assumes that the

functioning and behavior of all organisms are significantly influenced by an emotional system that is anchored in the life process” (Kerr & Bowen, 1988, p. 48). Therefore the act of secret keeping and the secret itself can be a result of multigenerational patterns and the emotional system.

**The emotional system.** Kerr and Bowen (1988) describe the emotional system as one of the most important concepts of the Bowen Family Systems Theory. It is the “natural occurring system in all forms of life that enables an organism to receive information (from within itself and from the environment), to integrate that information, and to respond on the basis of it” (Kerr & Bowen, 1988, p. 27). Many times secrets result in a range of emotions, including shame, guilt, and anxiety. By looking at the function of the family secret within multigenerational families, we can explore the secret and its function systemically. By looking at the function secrets serve within the family, we are able to move it from an individual focus to the family level and observe multigenerational patterns.

Family patterns and family secrets often repeat themselves. Sometimes this is done unknowingly. Keeping a secret can very well be a tradition within a family. This can lead to a legacy of secrets where the same or similar secret continues throughout multiple generations. For example, one individual is abused by a family member in one generation and the pattern continues in the next generation and the next generation, without either generations recognizing or being aware of the secret shared amongst them. In line with the concept of the emotional system, “much of the emotional functioning of the organism is geared to its relationship with other organisms and with the environment” (p. 29).

Because the family is considered an emotional unit, Kerr and Bowen (1988) explain that “people often function in ways that are a reflection of what is occurring around them” (p. 9). Therefore, “the thoughts, feelings, and behavior of each family member, in other words, both contribute to and reflect what is occurring in the family as a whole” (Kerr & Bowen, 1988, p. 9). As an emotional unit, the family can only be understood by looking at the individuals and the family as a whole, rather than in isolation of each other. This can be better understood by mapping families and the corresponding relationship processes and functions.

**Mapping family secrets.** The family diagram is a product of the Bowen Family Systems theory (Kerr & Bowen, 1988). It follows a basic format and uses standard symbols to record information about each nuclear family in a multigenerational family system (Kerr & Bowen, 1988). The genogram is a tool that expands on the family diagram and can be used to explore family dynamics and map family patterns (McGoldrick, Gerson, & Petry, 2008).

Genograms can also be used to track family history, relationships, and functioning (McGoldrick et al., 2008). Similar to the family diagram, the genogram can “help clinicians think systemically about how events and relationships are related to patterns of health and illness” (McGoldrick et al., p. 4). Genograms record individual and family information from, at the minimum, three generations. Graphing the information provides a visual to better understand patterns that have evolved throughout the family over multiple generations (McGoldrick et al.).

Family secrets are an issue that can be difficult to capture in a genogram. McGoldrick et al. (2008) explain that although it may be easy to depict who knows the

secret and who does not know, the amount of secrets can be a challenge. Where there is one secret, there may be others and illustrating the complexities of the secrets, such as how they are kept or shared through the family. Overcoming this challenge can help to see how secrecy functions in families.

By mapping, we can see how a secret is part of a larger context and has a larger function within the family. From the multigenerational point of view, you can see how that function continues over more than one individual's life span. Through mapping, we can explore the lived experience of individuals holding a family secret. We can also analyze the meaning found in holding a family secret.

### **Purpose of Study**

Kerr and Bowen (1988) explain that “when one examines relationship processes, one moves from thinking in terms of a collection of relatively autonomous individuals toward thinking in terms of the group as an emotional unit” (p. 38). The intention of the study was to examine the functions multigenerational secrets serve within the family, by:

- 1) exploring the lived experience of individuals holding a family secret, and
- 2) analyzing the meaning found in holding a family secret.

This was done by mapping multigenerational family secrets using the genogram. Semi-structured interviews were also conducted to aide in the exploration of the family secrets.

Family secrets can be a driving force, whether explicitly or implicitly, for many seeking therapy. By exploring and mapping the functions of multigenerational family secrets, the researcher conducted a study to examine in detail how participants are making sense of their lived experience with holding a family secret (Smith & Osborn, 2007). Conducting a phenomenology gave participants the opportunity to validate their



experience (Creswell, 2012). A phenomenology, as Creswell (2012) further explains, also helps to “reduce individual experiences with a phenomenon to a description of the universal essence” (p. 76). This helped families recognize the phenomenon of secrets within their own family and the phenomenon of secrets within the larger context of all families.

## CHAPTER II: REVIEW OF THE LITERATURE

Secrets are inevitable and some view them as part of the natural process (Kerr & Bowen, 1988). Vangelisti and Caughlin (1997) claim that nearly every family has secrets and that “some of these secrets are told” while “others are carefully hidden” (p. 679). Secrets shape our families and how we experience them (Bradshaw, 1995). General secrets are one thing but family secrets can be overwhelming. As Imber-Black (1988) explains, “Although we encounter secrets in every area of life, they are perhaps most destructive when kept in the home” (p. 52).

Everyone holds a secret, whether it's their own or someone else's. Bradshaw (1995) explains that “the ability to keep things secret is an essential power that all human beings possess in order to protect themselves (p. 5). This indirectly explains one function of secrets: protection. Although protection may serve as a function for maintaining secrets, one could assume that secrets may serve other functions. Bradshaw (1995) explains that “there is a large middle ground where secrets are neither destructive nor constructive as such but have to be judged by the way the secret is interpreted by a group, such as a family, and by how it functions in terms of the dynamic process and needs of that family system” (p. 7). This leads to the question: what functions do secrets serve within families?

As previously explained, secrets have a dual ability to draw one in and push one away. Imber-Black (1998) explains that,

Secrets at once attract us and repel us. The very same secret may be a blanket of protection one day and a bed of nails the next. It may provide warmth and

coziness in one relationship, while alienating us from other people with whom we long to feel close. (p. 22)

Bradshaw (1995) makes a similar claim in that the same secrecy that can bring about a sense of unity in an ethnic or religious group can also introduce prejudice and hatred toward those not of the same group.

Family secrets can be kept by the entire family from outsiders, they may be concealed by some family members from other members, and they may be held by individuals from the family (Karpel, 1980). A secret, according to Imber-Black (1993), “may be located within one individual, involving thoughts, feelings, or actions that the person has never spoken to another person” (p. 21). In fact, how a family defines secrets versus privacy may be defined by the function the information serves.

Privacy is necessary in order develop individuality and selfhood (Bradshaw, 1995). According to Papp (1993), “the issue of secrecy versus privacy involves not only internal family secrets but those that are shared among family members and kept from the outside world” (p. 70). When privacy is violated or a family no longer has boundaries of privacy, Bradshaw (1995) states, “Its members either resort to dangerous isolation or defend themselves with dark secrets rooted in toxic shame” (p. 11). Bradshaw refers to dark secrets as a perversion of privacy.

Karpel (1980) explains that “the boundaries created by secrets depend not only upon who knows the secret but also *knowing who knows*” (p. 296). On one end of the spectrum, if family members keep secrets from each other, and even outsiders, the emotional consequence can last a lifetime and over many generations (Imber-Black, 1998). However, in some instances, the secret can function to strengthen the boundary

between the family and outsiders when all family members know the secret and know they all know (Karpel, 1980). As explained by Imber-Black (1998),

In some families, each person knows that everyone knows a secret. In other families it remains unclear who knows and who doesn't know. Secrets may, in fact, be located within the family and known by all, but family members are separated and distant because of a secret about the secret. (p. 43)

In other instances, "certain secrets implicitly define hierarchy in relationships" (Imber-Black, 1993, p. 20). Therefore, secrets can hold power. As Imber-Black (1998) states, "secret knowledge becomes the currency of manipulation, and family relationships become a marionette show in which the teller pulls the strings" (p. 44). This, in and of itself, can have devastating multigenerational outcomes for families.

### **Family as a System**

Founders of marriage and family therapy define the family as a system (Minuchin, 1974; Satir, Stachowiak, & Taschman, 1975). Bowen (1971) explains that, "the family is a system in that a change in one part of the system is followed by compensatory change in other parts of the system" (p. 166). It is a system that is delicately balanced while struggling to maintain that balance, otherwise known as homeostasis (Bowen, 1971; Satir et al., 1975). According to Satir, Stachowiak, and Taschman (1975), sometimes that balance, or lack thereof, reflects family pathology.

In systems thinking it is important that we obtain some understanding of the influences that develop our view of the world (Noone, 1989). The system (family) is made up of subsystems (the individual family members) (Satir et al., 1975). The family, according to Minuchin (1974) "is a natural social group, which governs its members'

responses to inputs from within and without” (p. 7). A change in one part of the system (family) changes the balance of the system (Satir et al., 1975).

Individuals within a family are members of a system to which they must adapt (Minuchin, 1974). As families form, a child’s behavior and his or her sense of identity will be molded as part of the early process of socialization (Minuchin, 1974). To further explain, “The sense of separateness and individuation occurs through participation in different family subsystems in different family contexts, as well as through participation in extrafamilial groups” (Minuchin, 1974, p. 47). This explains why according to Vangelisti and Caughlin (1997), family relationships are shaped, in part, by what is shared and what is withheld by family members.

### **Bowen Family Systems Theory**

Bowen Family Systems Theory grew from a desire to look beyond individual pathology (Kerr & Bowen, 1988). The theory views human behavior from a family and natural systems perspective (Knauth, 2003). Bowen (1971) defines the central concept in this theory as the undifferentiated family ego mass. It is “an emotional process that shifts about within the nuclear family (father, mother, and children) ego mass in definite patterns of emotional responsiveness” (Bowen, 1971, p. 171).

Another key concept of Bowen Family Systems Theory is differentiation of self (Kerr & Bowen, 1988). Knauth (2003) explains that differentiation of self is “the degree to which one can separate one’s emotional system from one’s intellectual system, or the ability to keep emotions and thinking separate” (p. 333). This is a critical concept as it influences the others.

From a Bowen perspective, health is experienced by the family to the extent that each of its members is differentiated from the other members, is able to take an “I position,” and is able to adapt to life changes using intellectual functioning rather than emotional reactivity (McFarlane, 1988). The focus of Bowen Family Systems Theory is on the functioning of all families (Knauth, 2003). The long-term goal is to increase the individual member’s and the family’s functional level of differentiation of self (Knauth, 2003). This takes time as even the most intellectual are sometimes poorly differentiated (Kerr & Bowen, 1988).

According to Knauth (2003), “Bowen Family Systems Theory provides an understanding of the occurrence of family secrets and their effect on family functioning” (p. 333). Bowen Family Systems Theory views the family as an emotional system consisting of members who are attached by relationships with one another that influence their survival (Knauth, 2003). Kerr and Bowen (1988) explain that a differentiated family is one in which the members are connected but each member is able to be an individual.

Secrets, although their frequency and intensity may vary, can be found in every family. This suggests that families are more alike than they are different. Differences are simply a matter of duration and intensity (C. Burnett, personal communication, 2014). The presence of secrets, according to Knauth (2003), “represents intensity and anxiety in the family and limited family relationships, which are not the resources to family members that they could be” (p. 336). In fact, some would conclude that information becoming a secret is evidence of less differentiation of self. One could also conclude that there must be a fair amount of anxiety within the family holding a secret (Knauth, 2003).

There are eight concepts of the Bowen Family Systems Theory, but for the purposes of this study, the researcher focused on emotional system, anxiety, differentiation, triangles, and multigenerational transmission process to explore family secrets.

### **Family as an Emotional System**

The emotional system is one of the central concepts of the Bowen Family Systems Theory (Kerr & Bowen, 1988). Bowen recognized the interdependence within the family, thus identifying it as an emotional unit (Kerr & Bowen). Identifying the family as an emotional unit implies that “people have less autonomy in their emotional functioning than is commonly thought” (Kerr & Bowen, 1988, p. 9). The family as an emotional unit also suggests that people often operate as a reflection of what is taking place around them. Thus they are influenced by their environment (Kerr & Bowen).

The emotional system being the foundation also suggests that it influences everything else. While at the Menninger Clinic, Bowen and his research team “found that the same fundamental relationship process could be consistently defined in every family. This consistency was there despite the tremendous psychological variation between the families” (Kerr & Bowen, 1988, p. 10).

Kerr and Bowen (1988) further explain the human family as a natural system. Friedman (1991) goes on to expound that the emotional system “refers to any group of people...that have developed emotional interdependencies to the point where the resulting system through which the parts are connected...has evolved its own principles of organization” (p.144). Kerr and Bowen (1988) explain that while examining the relationships, we shift our thinking about individuals functioning in autonomy to thinking of the group as an emotional unit. With all parts being interconnected, no individual

functions in a vacuum. Each one is responding to other individuals, groups, and layers within the groups.

Kerr and Bowen (1988) state that “the functioning positions of family members are a manifestation of the emotional system” (p. 55). Friedman (1991) further explains that the family emotional system includes far more than just emotions, and includes the members’ thoughts and feelings. It also includes associations and past connections, both individually and together. It includes genetic heritage, thus the emotional system of the family also involves sibling position (Friedman, 1991). Therefore, sibling position can influence the different functions secrets serve within a family.

Kerr and Bowen (1988) state that “when we ask human beings why they do what they do, we are expecting a psychological explanation” (p. 31). Because it is so easy to get caught up in the “why” of things, we sometimes forget that humans “are motivated to do many things on the basis of processes that have roots deeper (older in an evolutionary sense) than thinking and feeling” (p. 31). Therefore, Bowen recognized that secrets are part of a family’s emotional process (Kerr & Bowen). When we can think in terms of survival, then we can better position ourselves to think in terms of function. Then, when we begin to think in terms of function, we may obtain important information and even understanding behind the motivation of an individual (Kerr & Bowen).

Friedman (1991) explains that the emotional system “concentrates the focus of what to take note of...and it reduces greatly the importance of the data that many other approaches to family therapy consider significant, if not vital, by seeing such information as the content rather than the driving force of emotional processes” (p. 145). With this in mind, we can attempt to explain certain parts of an individual’s actions in context of the



emotional system (Kerr & Bowen, 1988). This can expand our understanding of the function of behavior within the emotional system.

Kerr and Bowen (1988) explain that “the concept of the emotional system is one of the most important in family systems theory” (p. 27). The human family is a natural system, but it is a “particular natural system called an emotional system” (p. 26). A clinical implication of the emotional system is that once individuals and families are better able to understand each other and the system in which they function, they may be able to exonerate each other. This implication may hold true for the functions of secrets as well.

### **Anxiety and Differentiation**

**Anxiety.** Chronic anxiety is one of two principal components of the Bowen Family Systems Theory that explain level of functioning; differentiation is the other (Kerr & Bowen, 1988). Anxiety is a response to both real and imagined threats (Kerr & Bowen, 1988) and this has nothing to do with intelligence (C. Burnett, personal communication, 2012). It can be described as acute or chronic. Acute anxiety is mostly due to a real threat and is experienced briefly (Kerr & Bowen, 1988). It is also driven by fear of what is. Chronic anxiety, on the other hand, is usually in response to threats that are imagined and is experienced over a period of time (Kerr & Bowen). It is driven by fear of what *may* be.

While at the Menninger Clinic, Bowen treated residential schizophrenic patients and recognized the emotional impact between the patient and his relatives (Bowen, 1971). This led Bowen to observe the schizophrenic residential patients along with their entire nuclear families. Through these observations, he recognized the interdependence

between the patient and his or her family and thus developed the concept of the emotional unit (Kerr, 1988).

Later at Georgetown University, Bowen observed a broad range of clients and came to the realization that the relationship patterns he previously witnessed in schizophrenic patients were not exclusive, but were in fact present in all families (Kerr, 1988). Our egos lead us to believe that we are not as crazy as the next person, but Bowen often said “there is a little schizophrenia in all of us” (Kerr, 1988, p. 40). The difference is quantitative and not qualitative. As Kerr (1988) explains it, because we all have some schizophrenia, we consequently contribute to someone else’s schizophrenia.

Chronic anxiety “is influenced by many things, but it is not caused by any one thing” (Kerr & Bowen, 1988, p. 113). Nor is it caused by any one person. Family members usually associate their anxiety as being caused by an individual family member’s behavior, but rarely recognize the family member’s behavior as a reflection of their own anxious behavior (Kerr, 1988). An individual’s behavior is not just the function of the individual, but is very much a function of the family organization or emotional system that the individual is a member of (C. Burnett, personal communication, 2012).

There are many ways an individual manifests anxiety (Kerr, 1988). Relationships are recognized as the most effective binder, followed by substance abuse (Kerr & Bowen, 1988). Kerr and Bowen (1988) explain that the binding of anxiety in one system protects other systems; however, it can also be viewed that the binding of anxiety in one system is an individual’s *attempt* to protect other systems. For example, an individual may use

substances as a way to bind anxiety, but may in fact cause anxiety for not only the family, but society as a whole.

Anxiety begets anxiety and thrives on itself. As it begins in an individual, so goes the family. No one is ever anxious all by himself (C. Burnett, personal communication, 2012). When there is stress within the family, anxiety increases (Kerr & Bowen, 1988). Society as a whole may attempt to separate an individual's reasoning from his or her actions, but as Kerr and Bowen (1988) explain, "the amount of anxiety an individual is attempting to manage or bind cannot be adequately explained out of the context of the relationship processes of which he is a part" (p. 121). This is where differentiation comes in.

**Differentiation.** Differentiation influences the level of chronic anxiety. As Kerr and Bowen (1988) explain, "the lower a person's level of differentiation, the less his adaptiveness to stress" and therefore, "the higher the level of chronic anxiety in a relationship system, the greater the strain on people's adaptive capabilities" (p. 112). The development of symptoms is determined by the "amount of stress and on the adaptiveness of the individual or family to stress" (Kerr & Bowen, 1988, p. 112).

Differentiation within the emotional unit can indicate the level of anxiety within the unit. Kerr and Bowen (1988) explain that everyone is subject to acute and chronic anxiety but that the difference is based on responses that have been learned. Therefore "learning plays a large role in chronic anxiety" (Kerr & Bowen, 1988, p. 113). Members learn how to respond to situations and each other, thus chronic anxiety is primarily a response to a "disturbance in the balance of a relationship system" (Kerr & Bowen, 1988,

p. 113). Chronic anxiety of an individual and his or her family is a reflection of the differentiation of that individual and family (Kerr & Bowen, 1988).

Differentiation is the emotional interdependence one has in relationships and how that interdependence affects his functioning (Kerr & Bowen, 1988). It describes how people function in relationships (Kerr, 1984). There are two levels of differentiation that relate to functioning; basic and functional. Basic differentiation is not dependent on the relationship process, while functional differentiation is dependent on the relationship process (Kerr & Bowen, 1988).

The basic level of differentiation “is largely determined by the degree of emotional separation a person achieves from his family of origin” (Kerr & Bowen, 1988, p. 98). It is largely influenced by a multigenerational emotional process (Kerr & Bowen, 1988). In order to successfully change one’s basic level of differentiation to the family of origin, one must be “self-sustaining and living independently of his family” (Kerr & Bowen, 1988, p. 98). This may take years to achieve.

Functional level of differentiation is determined by the level of chronic anxiety in one’s significant relationship systems (Kerr & Bowen, 1988). It can be influenced by relationships, beliefs, culture, and religion (Kerr & Bowen, 1988). Kerr and Bowen (1988) explain that functional levels “can rise and fall quickly or be stabilized over long periods, depending largely on the status of central relationships” (p. 99). Therefore, there is a relationship between differentiation and anxiety.

By increasing one’s own level of differentiation, there is a reduction of chronic anxiety (Kerr & Bowen, 1988). In order to improve our individual level of differentiation, we must be more aware of and in control of our emotional reactivity (Kerr

& Bowen, 1988). An individual's change affects the whole system because of "interdependence of emotional functioning that exists between members of the same family" (Kerr, 1992, p. 102). On the same note, "one person's ability to be more of an individual in a family reduces anxiety throughout the system" (Kerr & Bowen, 1988, p. 132).

Many people use differentiation and individuality synonymously. However, as Kerr and Bowen (1988) explain, "differentiation refers to a process and individuality refers to a life force" (p. 95). Differentiation is a description of the process by which a person manages individuality and togetherness within a relationship system (Kerr & Bowen, 1988). It is on a continuum and there is gradation between the degrees of differentiation (Kerr & Bowen, 1988).

Differentiation is influenced by emotional separation. Kerr and Bowen (1988) state that "the degree of emotional separation between a developing child and his family influences the child's ability to differentiate a self from the family" (p. 96). Therefore, the degree of emotional separation that individuals achieve from their families of origin influences the levels of differentiation of self (Kerr & Bowen, 1988). The more one is differentiated, the more he can be an individual (self) while in emotional contact within a relationship system (Kerr & Bowen, 1988).

All family members are trying to achieve some level of differentiation, but in different ways. As Kerr and Bowen (1988) explain it, there are "differences among people in the amount of emotional separation they achieve from their families of origin" (p. 95). Therefore, to some degree, family members influence each other's

differentiation. Also, despite being raised by the same parents in the same household, not all children separate emotionally to the same degree (Kerr & Bowen, 1988).

Differentiation of self allows one to relate to the emotional system while maintaining some neutrality about it (Noone, 1989). Neutrality is the ability to be calm about what goes on between others while being aware of the emotional system and the influence of one's own subjectivity (Kerr & Bowen, 1988). Emotional neutrality is being outside the system with the "ability to see both sides of relationship issues and to be neutral about the fact that things are the way they are in one's family" (Kerr, 1984, p. 6). Thus, neutrality becomes differentiation when it is applied to one's actions in a relationship system (Kerr & Bowen, 1988).

From a systems perspective, behavior, such as secret-keeping, is understood based on its role within the system. Understanding the systemic process can help identify the role each person plays in the emotional system (Kerr & Bowen, 1988). This can in turn help reduce blame and prevent implication of cause to simply one person (Kerr & Bowen, 1988). It can also reduce anxiety and increase differentiation.

### **Triangles**

A secret may be located between two or more people in the family, thus excluding some while including others. The resulting shape is a triangle within the family and it sometimes creates loyalty binds (Imber-Black, 1993). The triangle is the preliminary part of an emotional system (Kerr & Bowen, 1988). Bowen (1971) describes it as "the basic building block of any emotional system" (p. 172). It is the "smallest stable relationship unit" that includes three people (Kerr & Bowen, 1988, p. 134). It is also a naturally occurring process within human relationships (Kerr & Bowen, 1988).

Anxiety is the primary influence of a triangle (Kerr & Bowen, 1988). As anxiety increases, a third person is brought into the system, thus creating a triangle (Kerr & Bowen, 1988). Anxiety is then reduced as it is now shared amongst the three people (Kerr & Bowen, 1988). A third person is automatically drawn in once anxiety builds amongst a dyad (Kerr & Bowen, 1988).

A triangle is also part of a larger system (McGoldrick, Gerson, & Petry, 2008). As Kerr and Bowen (1988) explain, “a particular triangle was not created necessarily by its present participants” (p. 135). Triangles are a fact of nature and last forever within families (Kerr & Bowen, 1988). The “emotional circuitry of a triangle...usually outlives the people who participate in it” (Kerr & Bowen, 1988, p. 135).

Triangles also cross generations (McGoldrick et al., 2008). The emotional system does not cease to exist with the deaths of individuals (Kerr & Bowen, 1988). The emotional system is rather carried down the generations through interlocking triangles (Kerr & Bowen, 1988). Once in place, the triangle will last, although the people involved may change (C. Burnett, personal communication, 2012).

According to Kerr and Bowen (1988), “it is not always possible for a person to shift the anxiety in a triangle” (p. 139). Therefore, the anxiety spreads to others and interlocks with other triangles (Kerr & Bowen, 1988). When anxiety is unable to be contained within one triangle and therefore involves one or more other triangles, they have become interlocking triangles (Kerr & Bowen, 1988). A benefit of interlocking triangles is that they can reduce anxiety in a family’s central triangle (Kerr & Bowen, 1988).

Kerr and Bowen state that “triangles appear to be universally present in human species” (p. 143). However, because triangles are identified as being part of the emotional system, they are capable of being observed in subhuman species as well (Kerr & Bowen, 1988). In addition, a live person is not a requirement for the existence of a triangle (Kerr & Bowen, 1988). Kerr and Bowen (1988) explain that a “fantasied relationship, objects, activities, and pets can all function as a corner of a triangle” (p. 136). Therefore, secrets can form triangles and thus function as a corner of a triangle.

Multiple and secret triangles freeze family relationships (Imber-Black, 1998). Imber-Black (1998) explains that “the creation of any secret between two people in a family makes a triangle” (p. 29). A secret between two people always excludes another and sometimes several others (Imber-Black, 1998). A secret between two people thus creates a threesome.

Triangulation is the process of bringing a third person into a dyad. It is the interdependent functioning of the three individuals within a triangle (McGoldrick et al., 2008). Kerr and Bowen (1988) understand triangles to be an instinctual process. They are the automatic emotional reactivity of people, one to one another (Kerr & Bowen, 1988). Therefore, secrets can be viewed as a form of triangulation.

Triangles are present everywhere. The process of triangling does not need to be taught or learned (Kerr & Bowen, 1988). Even in a brief gathering of three people, the relationship tends to become that of two insiders and one outsider (Kerr & Bowen, 1988). It’s not a matter of whether a triangle exists within the emotional system, but rather a matter of duration and intensity and the individuals involved (C. Burnett, personal communication, 2012).



Kerr and Bowen (1988) explain that “the intensity of the triangling process varies among families and in the same family over time” (p. 139). This is a result of undifferentiation. As stress becomes contagious within the system, more individuals may become triangled into the twosome (Kerr & Bowen, 1988). When triangles are shaped by secrets, they “can become especially convoluted as the existence of the secret-keeping dyad per se becomes a secret” (Imber-Black, 1993, p. 9). Triangles and secrets have a mutual effect on each other. Imber-Black (1998), in fact, states that “when triangles are underpinned by secrets, attempts by a family member to change a pattern or even express a new opinion are met with swift and vehement reactions” (p. 29).

Differentiation gives individuals the capacity to make a choice (Kerr & Bowen, 1988). When applying a systems perspective as a way to understand the emotional process in a family, people can “get beyond blaming, side-taking, guilt, anger, and other feelings and subjective attitudes that were incorporated in the atmosphere of the family emotional system and reinforced by societal attitudes about the nature of human problems” (Kerr & Bowen, 1988, p. 152). This can be done by detriangling. Kerr and Bowen (1988) describe detriangling as perhaps “the most important technique in family systems therapy” (p. 150).

Triangles are everywhere and nobody is immune from them (Kerr & Bowen, 1988). You’re either being triangled by others or triangling others yourself. Detriangling is part of the process of differentiation and requires emotional neutrality. Neutrality is “reflected in the ability to define self without being emotionally invested in one’s own viewpoint or in changing the viewpoints of others” (Kerr & Bowen, 1988, p. 150). Emotional neutrality is also the ability to see both sides of the relationship between a

dyad. It allows for processing that dyad relationship without ideas of what ‘should’ be (Kerr & Bowen, 1988).

Complete differentiation is elusive as no one is able to completely detriangle from any triangle (Kerr & Bowen, 1988). In addition, people will try to undermine one’s efforts to become more differentiated by defining more of a self (Kerr & Bowen, 1988). However, the process of achieving even a small amount of change can result in an increase of one’s differentiation (Kerr & Bowen, 1988).

Imber-Black (1998) states that “anytime the closeness of two people is the result of keeping a secret from one or more others, then the operative relationship is a triangle, not a duo” (p. 29). Genograms are a tool that can help to identify triangles within a family (McGoldrick et al., 2008). Incorporating genograms in sessions has helped clients to recognize that triangles are a natural process (Kerr and Bowen, 1988). Clients have also been able to identify the multiple effects that triangles have had throughout their family’s generations. Tracking triangles within a family system in turn helps to better understand the relationship process (McGoldrick, Gerson, & Petry, 2008). Recognizing the patterns within a family system helps to understand the behavior of any one member of a triangle as a function of the behavior of the other two (McGoldrick, 1988, p. 169).

Detriangling and differentiation is a lifelong process (C. Burnett, personal communication, 2012). They are one thing in theory and another in action. As Kerr and Bowen (1988) explain, “actions have more impact than words in a detriangling effort (p. 155). It’s those actions that can actually lead to change.

### **Multigenerational Transmission Process**

When secrets cross generations, they can become toxic (Bradshaw, 1995). Papp (1993) states that “among the most harmful kinds of secrets are those that involve hidden alliances and coalitions in families” (p. 68). Nuclear and multigenerational family secrets can lead to dysfunction within the family (Bradshaw, 1995).

Bowen (1978) observed that families repeat themselves and that patterns continued from one generation to the next. Through assessments, Kerr and Bowen (1988) found that “significant differences in levels of functioning can exist between members of different generations” (p. 221). Members are assessed to function on a continuum between the extremes of exceptionally stable and exceptionally unstable functioning. There can be a significant variance in the levels of functioning between nuclear families in different generations and even within the same generation (Kerr & Bowen, 1988).

The multigenerational emotional process or the multigenerational transmission process as defined by Kerr and Bowen (1998) is “an orderly and predictable relationship process that connects the functioning of family members across generations” (p. 224). The family systems assumption is that individual differences and multigenerational progressions will reflect this process.

Sometimes family members are required by other members to keep or maintain a family secret. This can create a double bind, especially when children are involved in secrets that cross generations. For example, collusion can occur when one parent shares a secret with a child and asks the child to not share it with the other parent. Therefore, in order to not betray one parent, the child must betray another parent by maintaining the

secret (Bradshaw, 1995). Bradshaw also explains that when generational boundaries are blurred or violated, children can become enmeshed in their parents' marriage, thus resulting in spousification.

Many children sacrifice their own safety and well-being out of fear or threat of family disintegration or worse if they open a secret (Imber-Black, 1998). Estrangement is another result of family secrets and can be created through various subsystems of the family based on who knows, who doesn't know, and who doesn't know who knows the secret (Papp, 1993). Hence, it is not uncommon for family members to threaten exposure of secret information in order to blackmail one another (Papp, 1993).

Imber-Black (1993) explains that "intergenerational family loyalties are often shaped by secrets" (p. 9). Therefore, not only is the secret a secret, but keeping the secret is also secret (Imber-Black, 1998). As part of the multigenerational transmission process, such loyalties may appear as otherwise unexplainable behavior that repeats throughout the generations (Kerr & Bowen, 1988; Imber-Black, 1993). When explaining family loyalty as it relates to family secrets, Imber-Black (1993) states that, The very meaning of family loyalty may narrow in the presence of required secret-keeping, such that a family member comes to believe that only by maintaining a secret can one demonstrate loyalty and that to open a secret is the supreme act of disloyalty. (p. 10)

Similar to the multigenerational transmission process, there can be many layers involved in the reasoning individuals resolve to keep family secrets. Kerr and Bowen (1998) state that the "multigenerational emotional process is anchored in the emotional

system and includes emotions, feelings, and subjectively determined attitudes, values, and beliefs that are transmitted from one generation to the next” (p. 224).

### **Function of Family Secrets**

Previous studies on the functions of family secrets are based in grounded theory. Vangelisti (1994) conducted a study amongst college students that summarized four functions of secrets, including:

- 1) create and maintain intimacy,
- 2) build and maintain group cohesiveness,
- 3) protecting the family structure, and
- 4) protect family members from social disapproval or rejection.

The factors underlying the functions of family secrets were: bonding, evaluation, maintenance, privacy, defense and communication (Vangelisti, 1994). The population of the study was limited to undergraduate students in a questionnaire format.

The current research of family secrets is limited to the functions and does not expand on the meanings or lived experiences of individuals holding family secrets. The research also doesn't explore family secrets multigenerationally. By incorporating qualitative methodology along with a Bowen Family Systems Theory approach, secrets and their impact on the emotional system can be examined.

### **Summary**

The primary purpose of the study was to move family secrets from an individual focus to the family level by exploring the larger systems (multigenerational) function of family secrets. By doing so, the researcher found that the family secret had a larger

context, and a larger function. From a multigenerational point of view, the researcher explored how that function continued over more than one individual's life span.

A secondary purpose of this study was to examine in detail the personal lived experience of those currently keeping or who have kept family secrets. This research answered how participants make sense of their experience and what meaning was found. These results have implications for the effects of family secrets and their influence on the emotional system from generation to generation.

## **CHAPTER III: METHODOLOGY**

Therapy is sometimes one's attempt to manage anxiety. In fact, reducing anxiety is essential to most models of psychotherapy (Kerr & Bowen, 1988). Kerr and Bowen (1988) explain that "sometimes just seeking help can reduce anxiety and, consequently, symptoms" (p. 126). This research is important as family secrets are a source of anxiety for many.

As previously expressed, this study sought to identify the functions that secrets may have served in participants' multigenerational families by:

- 1) exploring the lived experience of individuals holding a family secret, and
- 2) analyzing the meaning found in holding a family secret.

This began by mapping multigenerational family secrets using the genogram. Semi-structured interviews were also conducted to aid in the exploration of the family secrets.

A qualitative method was used in this study of multigenerational family secrets. Imber-Black (1993) describes secrets as systemic phenomena. The researcher completed a phenomenological study, specifically Interpretative Phenomenological Analysis (IPA). This allowed the researcher to explore both the individual, as well as common meaning of the lived experience of secret keeping for several individuals (Creswell, 2012). Ashworth (2007) explains that because phenomenology regards the individual as a conscious agent, the experience must be observed from the first-person perspective.

### **Phenomenological Research**

Phenomenology was founded by Edmund Husserl in an effort to take into account experience (Giorgi & Giorgi, 2007). Phenomenology begins with bracketing the question of a reality separate from the experience (Ashworth, 2007). This methodology is

concerned with the “primary reality, this thing itself as it appears: the ‘phenomenon’” (Ashworth, 2007, p. 11). Ashworth (2007) explains that “Human meanings are key to the study of lived experience” (p. 12). Phenomenological research, as explained by Giorgi and Giorgi (2007), “aims to clarify situations lived through by persons in everyday life” (p. 27). This method can be used to help the mental health field make discoveries about the experiential world in significant ways (Giorgi & Giorgi, 2007). Interpretative Phenomenological Analysis is an extension of phenomenology and explores the experience in its own terms (Smith et al., 2009).

### **Interpretative Phenomenological Analysis (IPA)**

Interpretative Phenomenological Analysis is a method of qualitative research which examines how people make sense of their major life experiences (Smith et al., 2009). Smith et al. (2009) explain that “IPA researchers are especially interested in what happens when the everyday flow of lived experience takes on a particular significance for people” (p. 1). This usually occurs when something major takes place in one’s life (Smith et al., 2009).

An Interpretative Phenomenological Analysis also allowed the researcher to obtain further insights that may not be afforded in other methodologies. As opposed to narrative analysis or grounded theory, IPA is founded in phenomenology, which studies perceptions, and hermeneutics, which studies interpretation (Ashworth, 2007). Similar to IPA, narrative analysis, extracts themes. However, narrative analysis also attempts to shape the different stories in an attempt to develop a story or plotline (Polkinghorne, 1995). Narrative analysis is focused on the individual *story* (Creswell, 2012), whereas



IPA is idiographic in nature, in that it is concerned with the individual *experience* (Ashworth, 2007).

This aspect of IPA also differentiates it from grounded theory, as grounded theory attempts to understand an experience in order to generate a general explanation from a large number of participants (Creswell, 2012). Grounded theory attempts to explain, whereas IPA attempts to understand. As Smith et al. (2009) explain, “When people are engaged with ‘an experience’ of something major in their lives, they begin to reflect on the significance of what is happening and IPA research aims to engage with these reflections” (p. 3). Therefore, an IPA researcher may be interested in looking in detail at how someone makes sense of a major experience in their life—such as a family secret.

Interpretative Phenomenological Analysis is an attempt to make sense of the participant’s experience and its meaning through reflecting, thinking, and feeling (Smith et al., 2009). According to Smith et al. (2009), “IPA is committed to the detailed examination of the particular case. It wants to know in detail what the experience for *this* person is like, what sense *this* particular person is making of what is happening to them” (p. 3). Interpretative Phenomenological Analysis aims to reveal something of the experience of each individual (Smith et al., 2009).

### **Participant Selection**

Interpretative Phenomenological Analysis is a methodology that generally lends itself to a small number of participants, because the concern of IPA is obtaining a detailed account of individual experience (Smith et al., 2009). Therefore, this study obtained data from five individuals from different families. Smith et al. (2009) state that the “aim is to find a reasonably homogenous sample, so that, within the sample, we can examine

convergence and divergence in some detail” (p. 3). As such, samples were selected purposively in order to gain insight into a particular experience (Smith et al., 2009).

Smith et al. (2009) also explain that with IPA potential participants are contacted via:

- 1) referral from various resources,
- 2) opportunities from one’s (researcher’s) contacts, and
- 3) snowballing, which are referrals by participants.

For this study participants were selected on the basis that they were able to share a particular perspective on the phenomena of multigenerational family secrets. Inclusion criteria for the study were that participants must be aged 18 years and older, English speaking, and willing to share and discuss a family secret. The exclusion criteria was anyone that did not meet the inclusion criteria.

### **Design and Procedure**

Geographical locations for the research included the tri-county area of South Florida, which includes Palm Beach, Broward, and Miami-Dade counties. The primary investigator (PI) informed local mental health professional and clergy contacts of the study. Some participants were invited to participate by another mental health professional or clergy member aware or informed of the study (Appendix A). Others were asked by other participants.

Participants received information explaining the purpose of this research study. All of the ethical guidelines outlined by the American Association for Marriage and Family Therapy (AAMFT), American Psychological Association (APA), and the Institutional Review Board (IRB) were reflected in the process of selecting, informing,

and interviewing participants regarding the research. At the commencement of the initial interview, the participants were asked to read and sign a consent form (Appendix B), which reviewed the purpose and design of the study. This also served as a confidentiality statement. Demographic information was obtained during the drafting of the genogram at the beginning of the interview.

Joining (building rapport) is necessary to encourage comfort and facilitate honest sharing of one's experience (Minuchin, 1974). This was aided by the creation and utilization of a genogram to map family history, relationships, and secrets. The purpose of the open-ended questions during the semi-structured interviews was to allow the opportunity for information to be shared during each meeting that was unique to each participant's experience, which may not otherwise be known.

### **Data Collection**

Participants were interviewed by a licensed marriage and family therapist who was supervised by a clinician specializing in Bowen Family Systems Theory. This ensured that the interviews followed a family systems approach and reduced bias when the data was analyzed. Interviews took place in one session lasting on average one hour each. The second interview was explained to participants as only being necessary if the first interview was interrupted or incomplete. Although this may be considered brief as it relates to Bowen Family Systems Theory (Kerr & Bowen, 1988), the purpose of the study was to explore secrets and some of the major concepts within the theory.

**Semi-structured interview.** As previously explained, at the beginning of the interview a genogram was drafted to identify multigenerational relationships and the history of family secrets. This was also used to ease anxiety considering the sensitive

topic in an effort to make participants more comfortable in sharing. Data collection continued in the form of semi-structured interviews, as usually done with IPA (Smith et al., 2009).

The purpose of this methodology is to analyze in detail participants' perception and how they make sense of an experience (Smith & Osborn, 2007). Therefore, flexibility is an advantage in this methodology. During such interviews questions are used flexibly to guide the dialogue, but as Smith et al. (2009) explain, the participant has an important role in what is covered. The order of the questions is not as important as the questions themselves. Using IPA, the researcher has an idea of interest to pursue, and at the same time has the opportunity, as Smith and Osborn (2007) explain, "to enter, as far as possible, the psychological and social world of the respondent" (p. 59). As a result, the participant can introduce or shed light on an issue the researcher had not originally considered or thought of (Smith & Osborn, 2007).

**The interview schedule.** During the semi-structured interview, the researcher had a prepared set of questions, referred to as an interview schedule (Appendix C), that was used in guiding the interview rather than dictating it (Smith & Osborn, 2007). The open-ended questions attempted to explore participants' experiences without limiting the experiences. Smith and Osborn (2007) explain that this form of interviewing "allows the researcher and participant to engage in a dialogue whereby initial questions are modified in the light of the participants' responses and the investigator is able to probe interesting and important areas which arise" (p. 57).

Although a semi-structured interview may have room for flexibility, Smith and Osborn (2007) explain that it is still important to create an interview schedule in advance.

This helped the researcher to consider what may have been covered in the interview. In addition to suggested questions, the researcher was able to think of possible difficulties that may have arisen, wording of questions, and sensitive areas or topics of discussion. Being intentional in preparing a schedule as Smith and Osborn (2007) suggest, helped the researcher to “concentrate more thoroughly and more confidently on what the respondent is actually saying” (p. 59).

**Recording.** Interviews were audio recorded and transcribed for data generation. Transcripts of the interviews were also collected for analysis. Interviews lasted an average of one hour each and every attempt was made to conduct the interview without interruption as suggested by Smith and Osborn (2007). The researcher used a family systems approach by exploring the emotional system, anxiety, differentiation, triangles, and multigenerational transmission process, along with drafting of a genogram to explore family secrets with each participant.

### **Data Analysis**

Analysis was completed as suggested for IPA (Smith et al., 2009) in order to learn about the participant’s world (Smith & Osborn, 2007). Because meaning is the central to IPA, the aim was to try and understand the content and complexity shared during the interview (Smith & Osborn). Analysis began with multiple readings of each transcript individually. Notes were taken and reviewed to extract any themes.

**Initial noting.** Smith and Osborn (2007) suggest that the left-hand margin be used to initially note anything interesting or significant in the participant’s response. At the outset, the transcript was read and then reread in order to become familiar with the

interview. Smith and Osborn (2007) explain that each reading may bring new information.

There are three elements to initial noting (Smith et al., 2009):

1. *Descriptive comments* are made initially to highlight the “objects which structure the participant’s thoughts and experiences” (Smith et al., 2009, p. 84). These exploratory comments are used to describe content.
2. *Linguistic comments* are concerned with language use. Some aspects of language to note include tone, pauses, laughter, and the use of metaphors.
3. *Conceptual comments* are more interpretative. This usually involves as Smith et al. (2009) explain, “a shift in your focus, towards the participant’s overarching understanding of the matters that they are discussing” (p. 88). Often there is an element of personal reflection during this stage of noting.

**Identifying themes.** After notes were made of the entire transcript, the researcher began again by taking notes in the right-hand margin. These annotations documented emerging themes. At this point, “the initial notes are transformed into concise phrases which aim to capture the essential quality of what was found in the text” (Smith & Osborn, 2007, p. 68). Once the transcript was noted of themes, the entire transcript was treated as data; therefore, omission or specific attention to some or any parts of the transcript was avoided.

**Making connections.** As part of the analysis, the study explored in detail the similarities and differences between each case (Smith et al., 2009). Annotated transcripts of the interviews were systematically analyzed case by case. The emergent themes were

listed in a separate document and a search for connections between the transcripts ensued (Smith & Osborn, 2007).

As themes began to cross between different cases, the clustering of themes began (Smith & Osborn, 2007). The clustered themes were checked in the original transcripts to insure that the connections being made were in line with the participant's actual words (Smith & Osborn). After clustering, a table representing the themes was produced.

At this stage, clusters were given a name and represented the superordinate themes (Smith & Osborn, 2007). The table listed the themes according to each superordinate theme. In order to assist in organizing the analysis, an identifier (number) was then added to each instance. Smith and Osborn explain that "the identifier indicates where in the transcript instances of each theme can be found by giving key words from the particular extract plus the page number of the transcript" (p. 72). This also helped to quickly identify the original source when needed (Smith & Osborn). During this process, certain themes were eliminated due to lack of substantial evidence in the transcript or failure to fit within the emerging structure. A final table of superordinate themes were constructed once each transcript had been analyzed.

**Writing the analysis.** During the final stage of the analysis, the concluding themes were written up in a final statement outlining the meanings of the participants' experiences (Smith & Osborn, 2007). A narrative account of the analysis was interpreted and presented in detail. The narrative was supported with verbatim excerpts from the participants (Smith & Osborn, 2007; Smith et al., 2009). Themes were presented, explained, and illustrated (Smith & Osborn, 2007). The genogram also illustrated and depicted any connections.

### **Ethical Considerations**

Due to the nature of the topic and the desire to make participants most comfortable, the interviews were held in their own home or a mutually agreed location. Upon completion of (or withdrawal from) the study, collected data (audio recordings and transcripts) will be maintained for 36 months and then destroyed. In order to maintain confidentiality of the participants, identifying information was protected by using pseudonyms (identified by an asterisk \*) chosen by the participant. Collected data was maintained in a secured safe in the researcher's locked private office within the residence where there was no access by others.

Participants were informed that participation was voluntary and discontinuation at any time during the study was allowable without reproach. It was understood that sensitive material may present throughout the course of the interviews that may require therapy. Upon request by participants, they were referred to a minimum of three mental health practitioners/practices for further or additional consult. No compensation was provided to the participants, however, therapy could have been referred as a result of their participation in the study. In addition, any material presented during the interviews that required mandatory reporting, such as abuse of minors and vulnerable adults, domestic violence in the presence of minors, and abandonment or neglect, was reported by the researcher.

Smith et al. (2009) explain that it is not possible to achieve a perfect interview technique. Because this topic is personal to the researcher, attempts were made at all times to recognize and journal biases and not lead the participant. The researcher used reflective listening to confirm with the participants about their statements and responses



to questions. Requesting clarification also assisted in reducing bias. These notes were also used in the following chapter to expand on the analysis.

## **CHAPTER IV: RESEARCH FINDINGS**

The decision to keep a secret is influenced by different factors and is therefore a unique experience. The anxiety revolving around the secret and the process of keeping it a secret can be intensified when the secret is about family, or involves particular members of the family. The participants of this study shared their experience about their decision to keep a family secret, the meaning found in the secret being kept, and the function keeping the secret served. The superordinate themes along with excerpts from the data are incorporated in this chapter and represent the various experiences presented by the participants.

Upon approval from NSU's Institutional Review Board (IRB), emails with the invitation (Appendix A) and consent form (Appendix B) were sent to professional contacts, which included colleagues and former classmates. Nine respondents expressed interest. The first five respondents which met the inclusion criteria were chosen for the study. Table 1 lists participant information. The interviews continued with questions related to family relationships in order to draft a genogram.

Investing time in the process of joining yielded considerable benefits. By facilitating honest sharing of their unique experience and by making efforts to provide a comfortable environment in which to do so, participants openly shared about the very things that they were supposed to keep secret. The order of the questions were specifically prepared in an effort to be sensitive to the topic shared. By intentionally beginning the interview with genogram questions about family history and relationships, participants were then eased into the traditional IPA questions that explored family secrets.

Table 1

*Participant Information*

Participant	Gender	Age Secret Revealed	Ethnicity	Primary Secret
Sam	Female	16	Afro-Caribbean	Father had an older son from a previous relationship
Brad	Male	30	Afro-Caribbean	Father is not biological father
Ron	Male	21	Asian	Brother is homosexual
Rebecca	Female	20	Afro-Caribbean	Sexual assault from cousin
Fay	Female	13	Afro-Caribbean	Identity of biological parents and mother attempted suicide while pregnant

The genogram questions were more benign and helped to build rapport which allowed the participants to share long held personal and family secrets during the interviews. The open-ended questions during the remainder of the semi-structured interviews allowed for particular questions to be asked related to the research questions, but also allowed for different questions that were unique to each participant's experience. This data could only be gathered through the personal interviewing process specific to IPA.

## Analysis

### Step 1: Reading and Re-reading

Smith et al. (2009) explain that immersing oneself in some of the data is the first step in IPA analysis. For this study, that involved reading and rereading the transcript. After the interviews were transcribed verbatim, the transcripts included line numbers and were then read without the audio recording and then reread with the audio recording. This first step in the analysis was to “ensure that the participant becomes the focus” (Smith et al., 2009, p. 82).

### Step 2: Initial Noting

The second step examined content and language and was therefore considered the most detailed and time consuming (Smith et al., 2009). During this stage the researcher noted anything of interest while identifying specific ways the participant spoke and thought about the phenomenon. Initial notes and exploratory comments were taken in the left margins on hard copies of the transcripts while rereading with the audio recording for the second time. During this initial noting, Smith et al. (2009) explain that there are no rules about what is commented upon and that the aim is to “produce a comprehensive and detailed set of notes and comments on the data” (p. 83). Exploratory comments were distinguished by:

1. *descriptive comments* that describe content and are illustrated with normal text,
2. *linguistic comments* that note language use and are italicized, and
3. *conceptual comments* which focus on interpretation and are underlined.

This was discerned on the hard copies using different colored highlighters. An illustration of the process in Table 2 contains a brief excerpt from an interview with Ron, a heterosexual male, speaking about his experience of keeping his brother's homosexuality a secret. The transcripts were reread with the audio recording for the third time and then without the audio recording several times to gain familiarity with the data.

Table 2

*Initial Comments*

Initial Comments	
Original Transcript	Exploratory Comments
<p>Researcher: So during that time period, what was your experience like living with that secret? Living with that secret being around your parents?</p> <p>Ron: Um, I definitely was against him coming out to our uncle and aunt, uh, that were, um yes. That he told them before my parents. Um, and I told him that because you're uh, making this circle bigger before the important people found out. And I was concerned about their feelings.</p>	<p>'Definitely' against brother going to other relatives first</p> <p>Used 'um yes' to complete the sentence describing his relative's homosexuality</p> <p><i>'Um' and 'yes' repeated Is there difficulty in articulating the homosexuality?</i></p> <p><u>Importance of keeping the secret within immediate family or disclosing to immediate family first</u></p> <p>Concerned about parents' feelings</p> <p><u>Protective of parents? Protecting them from the secret or finding out after others?</u></p>

### Step 3: Developing Emergent Themes

Emergent themes were developed during the third step. The exploratory comments were analyzed in order to identify emergent themes while focusing on sections of the transcript (Smith et al., 2009). This involved a hermeneutic effort while looking at the original transcript in relation to the parts and then putting them together to finalize the themes. Smith et al. explain that the importance of this step is to produce a concise statement from the different comments from a segment of transcript. This step is illustrated in Table 3 where notes were refined in the right margin. It was vital in this step to move from loose and open ideas found in the initial notes to emergent themes which reflected not only the participant's original words, but the researcher's interpretation (Smith et al.).

Table 3

#### *Emergent Themes*

Developing Emergent Themes		
Original Transcript	Exploratory Comments	Emergent Themes
<p>Researcher: So during that time period, what was your experience like living with that secret? Living with that secret being around your parents?</p> <p>Ron: Um, I definitely was against him coming out to our uncle and aunt, uh, that were, um yes. That he told</p>	<p>'Definitely' against brother going to other relatives first</p>	

<p>them before my parents. Um, and I told him that because you're uh, making this circle bigger before the important people found out. And I was concerned about their feelings.</p>	<p>Used 'um yes' to complete the sentence describing his relative's homosexuality <i>'Um' and 'yes' repeated Is there difficulty in articulating the homosexuality?</i> <u>Importance of keeping the secret within immediate family or disclosing to immediate family first</u> Concerned about parents' feelings <u>Protective of parents?</u> <u>Protecting them from the secret or finding out after others?</u></p>	<p>Keep it in the family  Concern for parents  Protecting parents from the secret</p>
--	---	---

#### **Step 4: Searching for Connections across Emergent Themes**

Themes were then listed chronologically in the order that they presented in the transcript. Some themes were included while others were discarded according to their relevance to the research question. Then the themes were clustered accordingly to become superordinate themes. Table 4 illustrates the process of this development. A complete list of the individual themes can be found in Appendix E.

Table 4

*Superordinate Themes*

Development of Superordinate Themes	
Emergent Themes	Superordinate Themes
Keep it in the family	Secrets as a means of protection
Concern for parents	
Protecting others from the secret	

**Step 5: Moving to the Next Case**

The next transcript was reviewed and the process (steps 1 through 4) is repeated during step five. Smith et al. (2009) explain that it is important to treat each case individually to reduce influence on what has already been discovered in the previous transcripts. This will help to allow new themes to emerge.

**Step 6: Looking for Patterns across Cases**

During step 6 the researcher looked for patterns across the different interviews. Connections were made between different transcripts and recurrent themes were noted. A master table of the themes (Table 5) illustrates this final step. Abstraction was the primary method used to identify patterns between the emergent themes. Similar themes (subordinate) between the cases were clustered and then given a name (superordinate themes). Other emergent themes were examined for their specific function in the transcript (Flowers et al., 2009). For example, the functions of family secrets was extracted from the function that language played in how the participants described their experiences and meanings.



Table 5

*Master Table of Themes*

Master Table of Themes	
Superordinate Themes	Subordinate Themes
What's in a secret?	Keep it to yourself
Living with a secret	Island mentality
	Faith and community
	Emotional effects
Finding meaning	What it means to me
Anxiety and differentiation	Burden of secret keeper
	Cutoffs and estrangements
	Forming triangles
Multigenerational transmission process	Generation to generation
Functions of family secrets	Secrets as a means of protection

**What's In a Secret?**

After completing the genogram questions, participants were asked to define a secret. By definition, secrets are formed by information that is purposely hidden (Vangelisti, 1994). In addition, there is a general assumption that secrets typically involve negative information (Afifi & Caughlin, 2006). This question was used to help participants recognize what they understood a secret to be, but also helped the researcher gain insight into what it meant to the individual participants. The different definitions helped shape the ideas of what participants define as truth and the meanings behind their family secrets.

**Keep it to yourself.** Brad defined a secret as “something that you do not share with everyone.” He added that a secret “generally has an element of either shame” or

“the potential to have a strain on relationships.” Fay defined secrets along the same lines explaining that they are “something that you keep yourself”. She described secrets as something of “disgrace” whereas Rebecca explained them as a way of “saving face”. Ron stated that “There are secrets that you keep all to yourself,” which he then described as the ultimate secret. According to him, these are the secrets that you take to the grave.

### **Living with a Secret**

Because IPA focuses on the lived experiences of the participants, it was important to ask questions that would provide data in response to that. Participants were asked about their experience living with the secret and asked other questions that would expound on the experience. The following subordinate themes were derived.

**Island mentality.** Some of the participants described their experience as somewhat of a cultural norm. When describing her father’s experience with having an unknown child outside of the marriage, Sam explained that “culturally” it was “not out of the norm”. Before closing with Brad, the researcher asked:

Researcher: Is there anything else you’d like to add before we end?

Brad: Um, no, this is quite prominent in Jamaican society. You know.

Researcher: Infidelity?

Brad: Infidelity and you know, keeping the secret, especially if the person is married, keeping that a secret, um, you know the outside kid syndrome you can call it.

Rebecca referred to the island mentality theme the most. She stated that her family believed that her grandmother fell ill at an early age due to all of the secrets she kept. She described her grandmother as “tight-lipped” and that “she just never let things out”

because of her being “island”. Regarding her cousin’s sexual assault, the researcher asked:

Researcher: So was that a secret with anybody?

Rebecca: That was, all of everything was a secret. That wasn’t something that you say or put out there. Um, that was their secret. I never heard it from them. I heard it from the girl that was being raped. And she tried to tell her mother or grandmother, whoever she was, what was going on. And because their island mentality, the grandmother blamed her and started pelting her and calling her a home wrecker. Instead of ‘oh my God, you’re a child and he raped you’.

To get a better understanding of what the island mentality meant to Rebecca, the researcher asked:

Researcher: So the island mentality is what? How do you define the island mentality?

Rebecca: Uh, just tight-lipped, keeping your mouth shut. If you say anything then, you know, I don’t know, just you don’t really, and if you hear about it, you don’t really spread it. Uh, you’re just hush-hush I suppose.

Although Ron did not speak of an island mentality, he did express the importance of keeping the secret in the family. However, his emphasis was on informing the “important people” before sharing with others.

**Faith and community.** Some participants directly linked faith, community, or both as having an influence in secrets being kept in their family or from outside knowledge. When asked:

Researcher: Why do you think your brother considered it (his homosexuality) a secret?

Ron explained:

Ron: Well, being raised in a Christian home, um, born and raised really, I mean from the time you were young, it was always church related activity. So he knew what the Bible says about being homosexual, and he knew that my parents were devout Christians, so he knew that, um, coming out to them would be very difficult, 'cause he already knew. He already knows their standpoint as far as that lifestyle goes. So that is probably the primary reason that he kept it a secret.

Both Fay and Brad described their families as being prominent in the community and being involved in the church. Fay explained the circumstances of her mother's pregnancy.

Fay: My mom got pregnant from my dad. They were first cousins. It was a disgrace because they were prominent people in their districts. And my mom was with my, was with her uncle to study. And she got pregnant and they shipped her back to her mom. And you know, my grandaunt took her because it was a disgrace there too. So they took her to neutral territory.

She was later asked why this was considered a secret and she replied:

Fay: Because it was a disgrace. Back in those days you just didn't have children out of wedlock. Didn't have them for your cousin. You know. And especially when you came from a family that was prominent in the community.

During the interview Fay brought up her faith. When asked about the role that faith played into keeping secrets, she responded:

Fay: My grandaunts, everybody in my family, were very actively involved in church. And they were always in leadership. They're always trying to mold people. And encouraging them to do what's right. So when a product of that environment does not adhere to the principles being taught, it creates a big problem.

Brad also spoke of his stepfather's prominence in the community. When asked about his mother's secret, he stated:

Brad: My stepfather was a very prominent Jamaican, so that's part of the reason why it was kept a secret. Because it could be said that his wife cheated on him and has this outside kid.

He added later about societal norms based on his culture. When asked about his family views on the secret, Brad replied:

Brad: We all feel my stepfather knew, but again, it was just part of society and you keep this kind of things a secret. Don't let these things be known.

Brad also shared that his grandmother's prominence in the church played a part in the secret being kept. When asked why this was considered a secret, he explained that:

Brad: Talking about shame and all of that, yeah, that definitely would have been a shameful thing for my mom –

Researcher: Ok.

Brad: And for her family. Um, my grandmother is very prominent in her church as well, so it would've been a shame that this famous guy, his wife cheated on him.

Researcher: Mmm hmm.

Brad: You know with this Rastafarian guy.

**Emotional effects.** Although this theme did not explicitly resonate with the majority of the participants, emotional effects played a role in the secret keeping.

Rebecca shared about her experience keeping the secret and how the resulting emotions kept her from sharing with her mother.

Researcher: What made you not share the other thing about the other cousin's advances, what made you not share that with her until your twenties?

Rebecca: I don't know. I think I felt, it's not that far away, but it feels like it was really far away. I, I think I just felt a lot of shame. Like I did something.

Researcher: Mmm hmm.

Rebecca: Even though I know I didn't. That's what they say people classically do, and you know, blame themselves and self-hatred.

Blah, blah, blah. But I really felt like it was a shameful thing and embarrassing.

Later in the interview, Rebecca went on to say:

Rebecca: Uh, it wasn't helpful. I just didn't want to hurt her (mom's) feelings. And I felt nasty. Like I was dirty. Did something wrong. But it didn't really help any situation.

Karpel (1980) explains that "Individual family members and the family as a whole suffer from the loss of relational resources that result from secrets" (p. 298). This can be witnessed in the in the statements that Brad shared about lost time with his siblings and the loss of a full sibling (his sister which he previously thought was his full sibling). When asked about his experience living with the secret, Brad shared:

Brad: So I felt a lot of time was lost. Um, to the point now where I don't have any interest in getting to know him better.

And he later stated:

Brad: And you know, one of the things I think does stick with me really strongly is that I don't have any full siblings.

Researcher: Is that a negative?

Brad: Definitely a negative. So, um, yes. I don't have any full siblings. All my mom's kids are my half siblings. All my dad's kids are my half siblings. So, you know, if there's a, with my mom, I could join with my siblings, you know, because it's all my mom. But sometimes I think, when my dad passes away, it's going to be my dad and your dad.

Brad also shared about his concern being predisposed to his father's unfaithful behaviors.

Researcher: Was that something you ever considered before that secret?

Brad: Did I? No, because I wanted to be like my stepdad. So yeah, I mean, I feel like there is. I don't know, kind of like you're predisposed to certain behaviors because of who you're connected to biological. Biologically. So having considered all he brings to the table –

Researcher: Mmm hmm.

Brad: And then knowing all he brings to the table is so negative, then, yeah, that's definitely an experience that I constantly think about. Um, and then all that time lost with my siblings as well.

### **Finding Meaning**

Interpretative Phenomenological Analysis also explores the meanings found in the lived experiences. Participants were asked about the meanings of the secrets. The following subordinate themes were extracted from the responses.

**What it means to me.** Participants were asked about the meaning that the secrets had for them. Sam expressed that the secret being held had no meaning to her. This may be due to the fact that she identified her brother as her father's son and views their relationship as "neither here nor there". When asked about the meaning of the secret being held, Rebecca replied:

Rebecca: I choose not to let them mean anything to me. Because it's not my life or my lifestyle or my choice of who I interact with.

For Fay, this question seemed to evoke an intense response. She quickly replied:



Fay: It means that I wasn't wanted. You know... putting it bluntly.

Ron had a similar response due to being close to his brother.

Ron: Well, I was definitely hurt when I first found out. Uh, that's what it means to me. That he, um, he couldn't trust me with that secret he had. Um, like I said, we were very close when he was still down here (Georgia\*) before he moved.

Brad was the only participant who responded positively about the meaning of the secret being kept. He described his mother keeping his biological father a secret as love, sacrifice, and a necessity. He explained:

Brad: Um, yeah, it means, it meant to me that someone wanted me to have a better. Like they felt my biological dad could not provide that for me. So the opportunities that I did have, to travel, and to have a good education, and all that stuff, you know, my mom felt that was the best thing for her and for me at the time. So, that, definitely, is a sign of love. Um, sacrifices to some extent. I don't know if she loved my biological dad, but, um, she definitely wanted to see the best for me. So that secret was absolutely necessary in that regard.

### **Anxiety and Differentiation**

Most participants did not identify any anxiety with maintaining the secret or burden of being the secret keeper. However, it can be interpreted that the desire to protect others from the potential damaging effects of a secret is a result of an attempt to manage anxiety. This was especially true for participants whose roles included that of

secret keeper. As Papp (1993) explains, “Although the event itself may be kept secret, the intensity of the feelings surrounding it is difficult to disguise. The very act of keeping the secret generates anxiety...one must be constantly on guard against disclosure, avoiding particular subjects and distorting information” (p. 66).

As previously expressed, acute anxiety is mostly due to a real threat driven by fear of what is, while chronic anxiety, is usually in response to threats that are imagined and is driven by fear of what *may* be. When individuals are keeping secrets of their own and even others, there is potential for anxiety. The level of anxiety is influenced by the secret and the time and intensity of the burden to keep the secret a secret.

**Burden of secret keeper.** As the keeper of the secret, the assumption is that there are varying degrees of anxiety. These degrees are exacerbated depending on who the secret affects and the circumstances surrounding who knows, who doesn't know, and the risk of the secret being exposed. Ron was asked specifically about his experience living in his parents' house knowing his brother's secret.

Ron: Not that it would ever come up in conversation, but, you know, just speaking to them plainly, day to day basis, knowing this is, um, you know, hanging above my head.

Researcher: Did you ever feel that your parents knew that you were keeping something from them?

Ron: Um, probably. Yeah, probably. And also, you know, just that feeling carrying this burden now. That it's, um, his secret but now I'm forced to keep my mouth shut about it.

Ron's burden can also be interpreted as loyalty to his brother and his brother's secret. During Brad's interview, he shared about his mother's cancer being a secret. When asked about his experience keeping his mother's illness a secret, he replied:

Brad:            Yeah, it was very difficult because she would need medical attention and she needed specific things taken care of, so there's all these questions with what's going on. Like why is this issue taking place. There was a constant sidestepping of the issue.

Brad also shared about keeping his brother's "outside" (extramarital) child a secret. Fay simply described her experience as feeling the need to keep her mother's suicide attempt a secret in order to protect her.

During the interview with Sam, she matter-of-factly dismissed the possibility of her having anxiety surrounding her family's secrets. However, when asked about the function that the secret served in her family, Sam replied:

Sam:            I'm always apprehensive about men.

She later added that:

Sam:            So whatever happens here (in her household) is open for discussion. In other words, what it does to me is hold everyone accountable at a higher ethical and moral standard of being so that, uh, the home is not a safe haven, the home is not a place where you can hide the dark secrets or the darkness in your personality. A home is safe. And if, and it's transparent.

Anxiety is influenced by differentiation and can also be expressed through cutoffs. In an effort to keep a secret a secret, or distance oneself from a secret, or the

people or places involved with the secret, individuals will cut themselves off physically and emotionally. An emotional cutoff is one way people manage undifferentiation between generations that can be enforced through physical distance (Kerr and Bowen, 1988). These cutoffs lead to estrangements and may take more effort to maintain than a non-cutoff relationship.

**Cutoffs and estrangements.** Rebecca did not state outright that she experienced any anxiety; however, she did state that she kept her cousin's sexual advances towards her a secret away from her mother in an effort to protect her mother. Rebecca also explicitly stated multiple times throughout the interview she was either estranged from her father's side of the family or wanted nothing to do with them. When explaining a fight that took place between her father and brother, she explained:

Rebecca: I don't want anything to do with my father or that side of the family. I always call it that side because there's nothing good. It's evil and disgusting and death and nastiness in my opinion.

In her desire to be more differentiated, portions of the interview with Rebecca displayed just how much anxiety revolved around being with or even talking to her father and his side of the family. This is a common example where people attempt to cutoff family by stopping or lessening visits or conversations with family. However, physical distance does not amount to emotional distance (Kerr & Bowen, 1988).

**Forming triangles.** Triangles begin with at least two people. Kerr and Bowen (1988) explain that a triangle does not require a third live person. It can include a fantasy, object, or a pet. Therefore, triangulation can include another individual or even a secret. Figure 1 illustrates the process. The triangle is formed as anxiety increases. During the process another individual is introduced into the dyad and anxiety decreases (Kerr & Bowen, 1988).

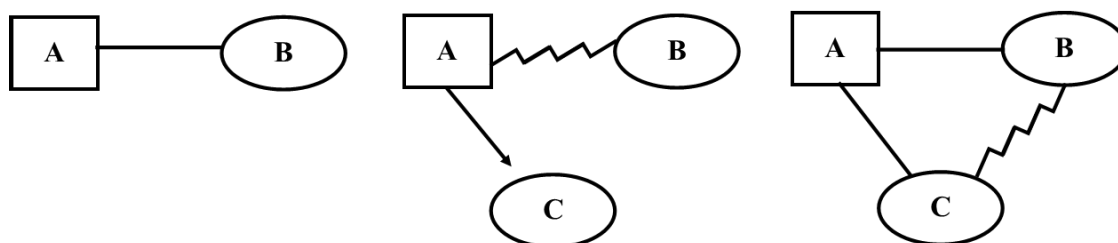

*Figure 1.* Triangulation. The left diagram indicates a calm relationship. The center diagram demonstrates conflict between A and B, and then A triangling C. The right diagram is the resulting triangle and shows how anxiety is now decreased. Adapted from Kerr and Bowen, 1988.

Ron shared how he became aware of his brother's homosexuality from his sister.

This illustrates how a triangle was formed:

Researcher: And you said that your sister was the one that revealed it to you?

Ron: Mmm hmm.

Researcher: Ok. And was she, when she came to you she said that she thought you already knew?

Ron: Right.

Researcher: So when she was discussing it with you...

Ron: Mmm hmm.

Researcher: She was talking to you like ‘Hey how come you didn’t tell me?’  
or...

Ron: Well, under the pretense that ‘Hey, do you know about, um, our  
brother?’

Researcher: Mmm hmm.

Ron: And you know the lifestyle he’s living or how he’s living up there  
in Indiana\*.

Researcher: Mmm hmm.

Ron: And I said, ‘Yeah, sure, um, he has this apartment.’ Which we later  
found out, he was not, he has not been living in since he moved in  
with the boyfriend.

Researcher: Ok.

Ron: And um, yeah that’s how I found out.

Researcher: Um, would you say that was explosive, like a bomb was dropped?

Ron: Yes. I was definitely in shock.

Ron shared about the close-knit relationship he shares between his siblings. In an attempt to reduce her own anxiety about discovering her brother’s homosexuality, Ron’s sister contacted him to alleviate her own shock; thus, triangulating him in the process (illustrated in Figure 2). She was previously unaware of their brother’s homosexuality and was introduced to the boyfriend during her visit.

Ron also shared his concerns with his brother “coming out” to his aunt and uncle before informing his parents.

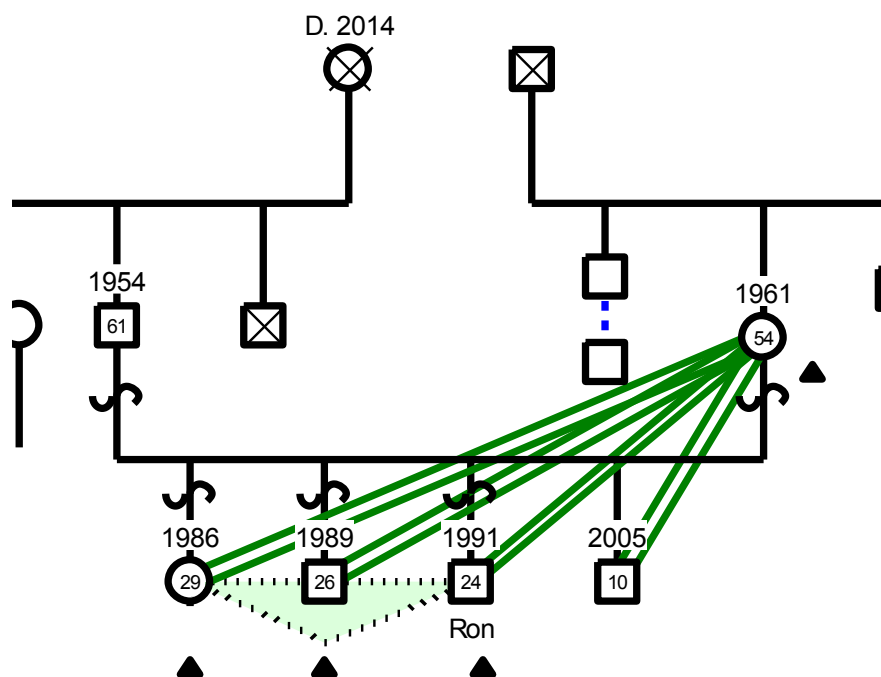

*Figure 2.* Ron's triangle 1. This figure illustrates the triangulation between Ron and his siblings.

Researcher: So during that time period, what was your experience like living with that secret?

Ron: Living with that secret being around my parents?

Researcher: Mmm hmm.

Ron: Um, I definitely was against him coming out to our uncle and aunt, uh, that were, um yes. That he told them before my parents. Um, and I told him that because you're uh, making this circle bigger before the important people found out. And I was concerned about their [parents'] feelings.

Researcher: About your parents' feelings?  
Ron: Mmm hmm.  
Researcher: About being [sic] wanting to know first?  
Ron: Right. Or you know, these, this amount of people knew about it before us and we've been around you and you're just, you know, you had this secret.

Ron was concerned about his parents' feelings and how this would impact them, especially considering how close his family is. This inevitably created another triangle (Figure 3).

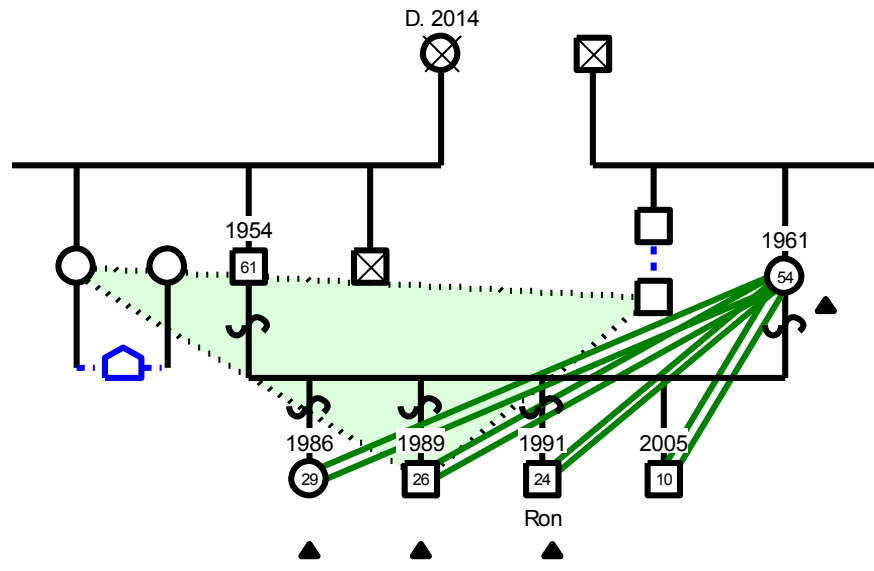

Figure 3. Ron's triangle 2. This figure illustrates the triangulation between Ron's brother and his aunt and uncle.

As previously expressed, some secrets cross generations. Fay shared about growing up with her grandaunts and the secret that her aunts kept from her regarding her biological parents and her mother's attempted suicide.

Researcher: Can you please tell me how you first became aware of this secret?



- Fay: My grandaunts told me.
- Researcher: Do you know why they told you?
- Fay: Yeah, because they wanted me to know that I didn't have a mother. That they took me in. I was basically theirs.
- Researcher: How old were you when you found out about this?
- Fay: I don't remember. Maybe about 13.

Fay went on to share about her relationship with her grandaunts and maintaining the secrets between them. Anxiety is usually the influence of a triangle formation. The triangulation in Fay's family (illustrated in Figure 4) continued as her grandaunts raised her as their child.

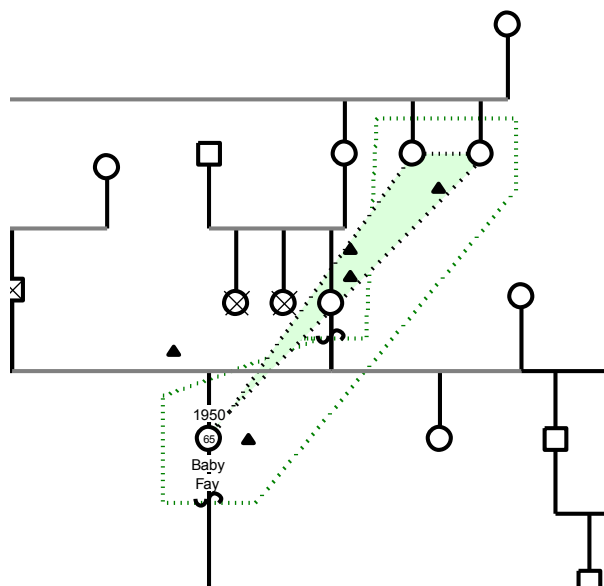

*Figure 4.* Fay's triangle. This figure illustrates the triangulation between Fay and her grandaunts.

### **Multigenerational Transmission Process**

The multigenerational transmission process (or multigenerational emotional process) of the Bowen Family Systems Theory assumes that the individual differences in functioning and multigenerational patterns are predictable. This relationship process is

what Kerr and Bowen (1988) state that “connects the functioning of family members across generations” (p. 224). The multigenerational transmission process is based in the emotional system and indicates what is transmitted from generation to generation. This includes emotions, feelings, attitudes, values, and beliefs. For this study, the focus was on secret keeping.

**Generation to generation.** Each participant was asked about their family and how secrets were transferred from generation to generation. Additionally, they were asked how they were informed, explicitly or implicitly, about how secrets are kept in the family. Sam explained:

Sam: I was raised where children are seen and not heard, so, I didn't have a voice.

When asked about how she knew about her family's expectations related to secrets, she explained:

Sam: Like I said, children are seen and not heard. And that's something throughout my entire family. And also, what happens in this house, stays in this house. So, there's a lot of unspoken.

The researcher also asked:

Researcher: How do you know that you're not supposed to share anything?  
Were you told that or is that –

Sam replied:

Sam: Yeah I was told that what happens here stays here. You don't share it with anyone.

Ron had a different response to the question. His response seemed positive, explaining that he witnessed his parents' relationship with their siblings and modeled that relationship with his brother. The secret was initially kept at the sibling level, similar to his parents homosexual siblings, but the secret was exposed and his brother was embraced despite his "lifestyle."

Ron: Um, mainly it was, uh, how my parents interacted with their siblings. They showed, um, that they had great relationships with their siblings; very tight bond. And um, they did, you know, keep secrets I guess from their parents as well amongst themselves and that we might have overlooked or heard about. And then, growing up we just saw that.

### **Functions of Family Secrets**

Exploring the multigenerational transmission process helped to better uncover the functions of family secrets. In systems thinking, "a particular behavior is understood in terms of its function in the system in which it occurs" (Kerr & Bowen, 1988, p. 134). Considering function aids in understanding motivation. This is the main premise of family theory as it "attempts to explain certain aspects of an individual's behavior in the context of the function of that behavior in the emotional system" (p. 49).

**Secrets as a means of protection.** One of the most common reasons for maintaining secrets is for protection (Imber-Black, 1998; Mason, 1993). This was the most expressed reason from the participants as to the function that keeping secrets served in their respective families. Some participants kept a secret to protect their mothers or siblings, while others recognized their mother's intention to keep a secret was a means of

protecting them. When describing his mother's affair, Brad described how his mother kept this a secret as a means of protection for them both.

Brad: So then, you know, Christianity, the religious part of it. So, Christians don't get with Rastafarians because they're considered ungodly. So the shame and disgrace that would come as a result of that would definitely, um, (pause) it was also used as a means of protection. I think I mentioned something of that in the definition.

Researcher: Protecting you or protecting your mom or both?

Brad: Both.

Fay described her experience as a desire to protect her mother.

Researcher: Can you please tell me about your experience having to keep that secret a secret from other people? Like your experience with talking with your friends about parentage or having to be around your mother –

Fay: It's just nothing I never [sic] thought about sharing with anybody. I knew and I, I loved my mom, and I don't want anybody to think bad of her. So, you know, I don't want her to experience any pain from it. I want to protect her.

### **Incorporating the Genogram**

Secrets were depicted in the genogram with a small black triangle (▲). As secrets were revealed, they were drawn on the genogram and later illustrated through GenoPro, a genealogy software designed to capture family trees. Illustrating the different participant genograms proved especially helpful as more family members and

relationships were added throughout the interview. It was also beneficial as secrets began to surface and helped to keep order of who was involved and who the secrets impacted.

During the analysis, secrets were noted in the left hand margin with an encircled letter S (( S)). This helped to keep track of the number of secrets shared in the individual interviews to later capture in the genogram.

**Sam.** Sam did not share many secrets during the interview and stated that she has an open relationship with her husband and son in an effort to promote honesty. Also, in hopes of being different from her family of origin, she hopes that this trend will be transmitted for future generations. Sam's genogram is depicted in Figure 5.

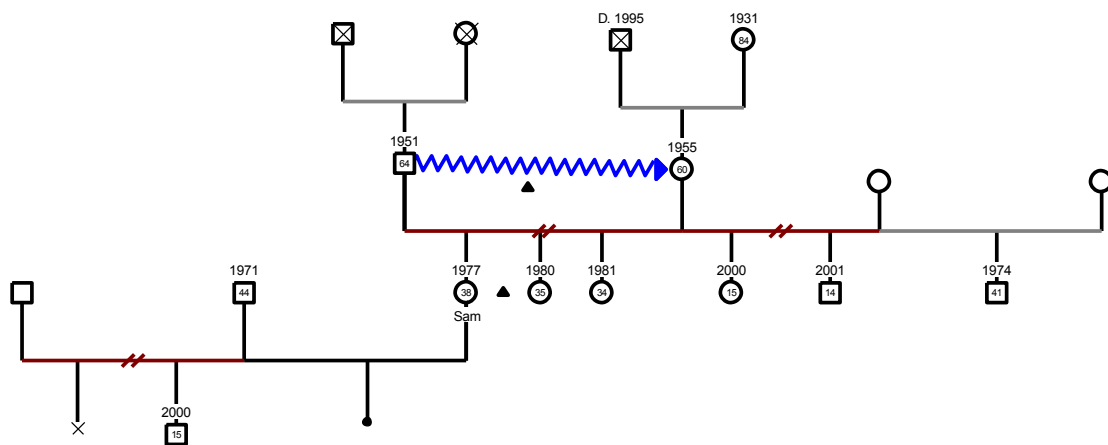

*Figure 5.* Sam's family secrets. This figure illustrates the number of family secrets in Sam's family.

**Brad.** Brad shared about his family secrets and explained at the end of the interview that there were more secrets to share (Figure 6). He added that one of his biological father's mates is also the biological daughter of his stepfather from a previous relationship. He added that years later it explained why there was contention between his mother and this woman. He initially thought it was due to the traditional challenges that may arise between stepmother and stepdaughter, but once that secret relationship was revealed, the contentious relationship between the two made more sense to him.

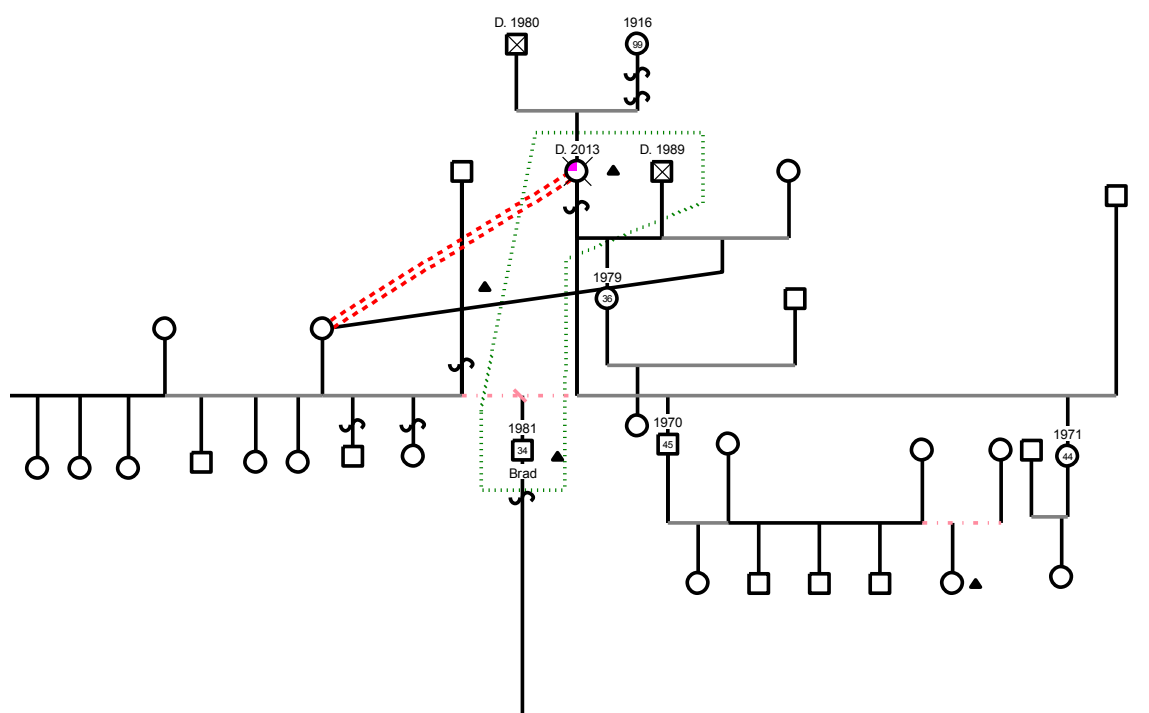

*Figure 6.* Brad's family secrets. This figure illustrates the number of family secrets in Brad's family.

**Rebecca.** Rebecca shared the most family secrets. Her family secrets are illustrated (Figure 7) in this genogram excerpt. Rebecca shared about various family secrets and made a comment referencing the challenge with tracking them during the interview:

Rebecca: It just gets really convoluted. I don't know how it stays in my head.

Although this was not a secret, Rebecca also shared about her grandparents being engaged and not marrying and her parents being engaged and not married. She also shared about the domestic violence that took place between her grandparents and then again with her parents. Infidelity was also displayed by her father and grandfather. These are patterns or reflections of the multigenerational transmission process. When speaking of her mother's choice to be with her father, she stated:

Rebecca: It's just part of that whole mindset. Maybe she was looking in the wrong place [for love].

Drafting the genogram helped to give life to the different relationships and keep order of the placement of secrets.

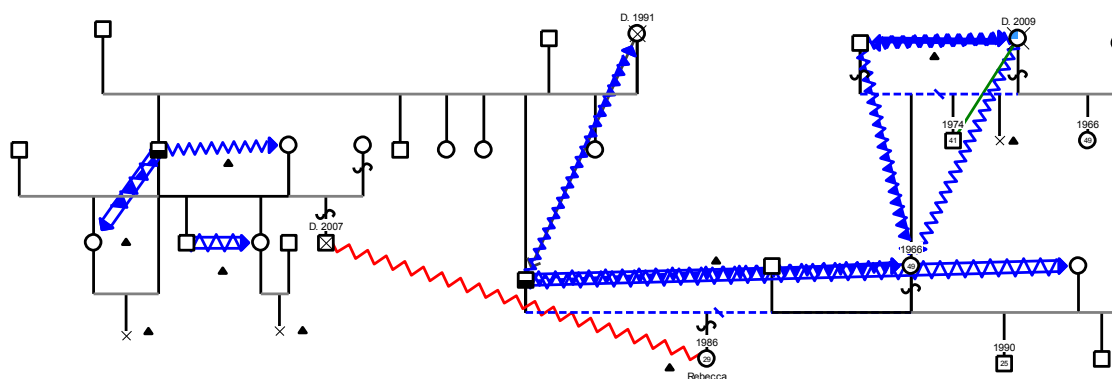

*Figure 7.* Rebecca's family secrets. This figure illustrates the number of family secrets in Rebecca's family.

**Ron.** Ron shared the least amount of secrets (Figure 8). He stated that his family is close and that there are not many things left unshared between them, which was why it

was a shock to him that his brother kept his homosexuality a secret. However, with most secrets, where there is one, there may be another. This may prove true within Ron's family as he shared about a most recent discovery:

Ron: Yeah, from our, from our teenage years up to that point, he did keep that a secret. I don't know if it's relevant, but what recently came out, or from what I recently learned about, um, my mom actually walked in on him with another guy, when that was about high school.

Researcher: Ok.

Ron: And she kept that a secret from everybody.

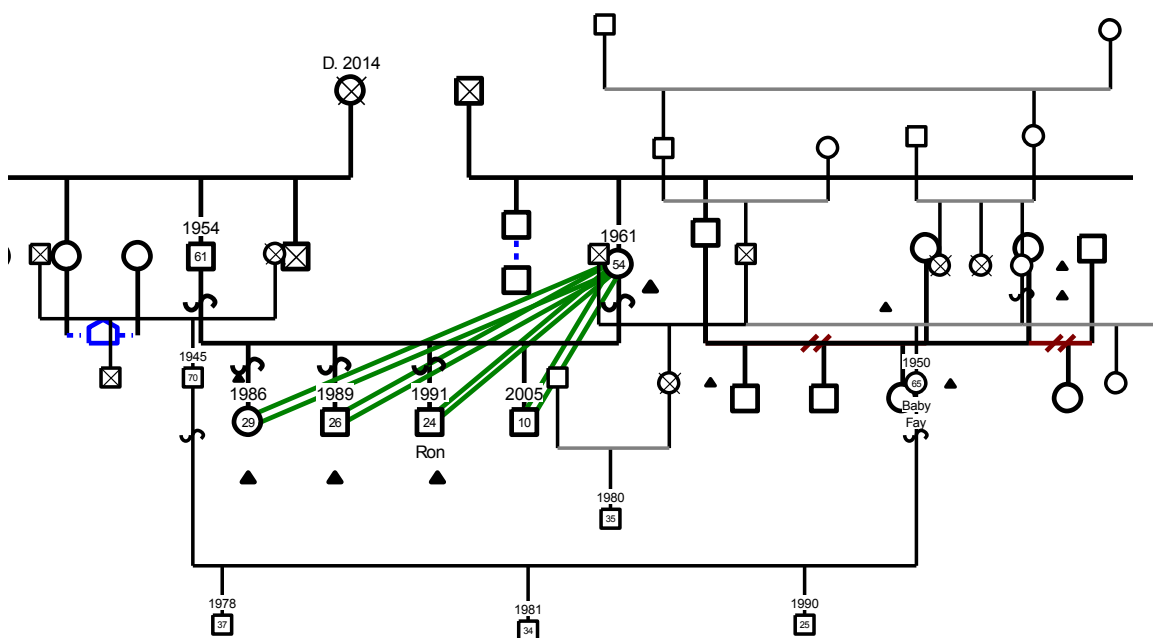
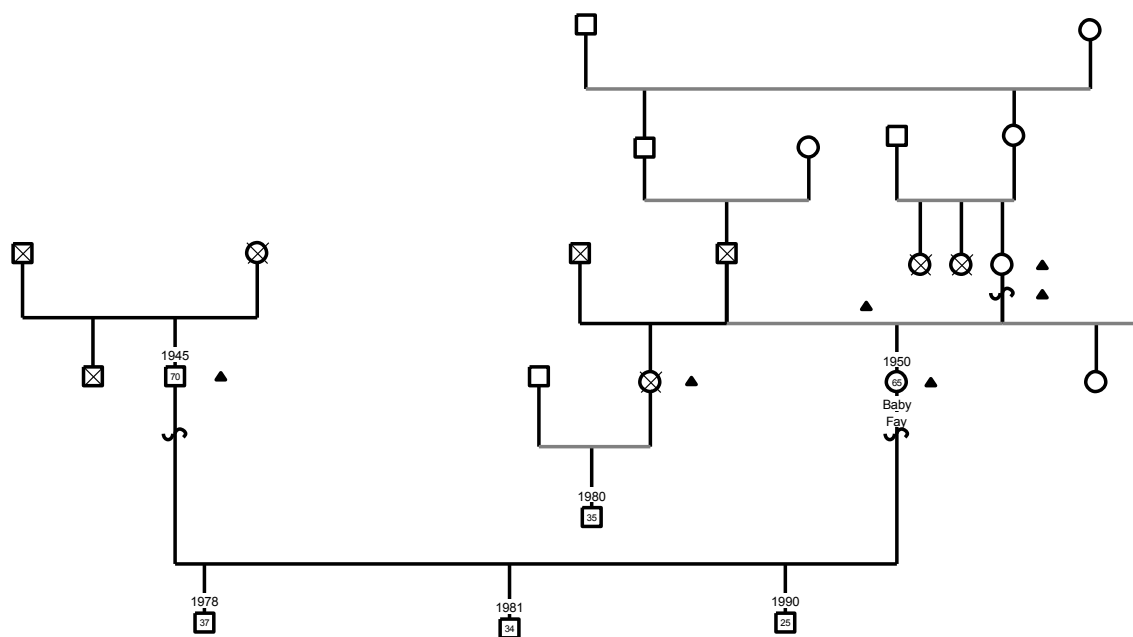

*Figure 8.* Ron's family secrets. This figure illustrates the number of family secrets in Ron's family.

**Fay.** Fay shared about her family secrets and explained that she imagines her mother would have quite a few secrets. Although she answered the questions asked



during the interview, she did not share more than what was asked, so the semi-structured questions were helpful in that it left room for additional questions to be asked as necessary. Fay did share about her marriage and described it as shaky. She also shared about living with her grandaunts and her mother's attempt to get away from her secret by moving away. Her family is depicted in Figure 9.



*Figure 9.* Fay's family secrets. This figure illustrates the number of family secrets in Fay's family.

Genograms were an integral part of this study. Including this component added to the depth of the standard IPA interviewing process as participants' individual experiences were brought to life through the illustration of their family relationships. By combining the interviews with the genograms, a depiction was made of the quantity of family secrets and the relational effects they may have had on the emotional system. This also quantifies the effects of those impacted by the secrets.

## Summary

This study utilized the qualitative method of Interpretative Phenomenological Analysis (IPA) to explore the experiences of individuals who have held a family secret and analyzed the meanings found in holding a family secret. The purpose of this study was to move family secrets from an individual focus to an examination of the family by exploring the larger systems (multigenerational) function of family secrets.

Each participant contributed different aspects of their experience of secret keeping, and during the analysis, connections were recognized across the different cases. As themes developed, their frequency amongst participants was noted. Table 6 illustrates the recurrence of the superordinate themes. This indicates, as Smith et al. (2009) suggest, “Whether the superordinate theme is present for each participant and then calculates whether it is therefore prevalent in over half of the cases” (p. 107). As previously stated, secrets as a means of protection was expressed by all participants to have served as the function for keeping secrets in their families.

Interpretative Phenomenological Analysis was chosen because of the structure of the methodology which allowed for each participant to share their unique experience. Semi-structured interviews, along with the drafting of a genogram, were used to gather data. The genogram was also used to depict the different family relationships and family secrets.

Table 6

*Recurrent Themes*

Superordinate Themes	Recurrent Themes					Present in over half sample?
	Sam	Brad	Rebecca	Ron	Fay	
Keep it to yourself	No	Yes	Yes	Yes	Yes	Yes
Island mentality	Yes	Yes	Yes	No	No	Yes
Faith and community	No	Yes	No	Yes	Yes	Yes
Emotional effects	No	Yes	Yes	No	No	No
What it means to me	No	Yes	No	Yes	Yes	Yes
Burden of secret keeping	No	Yes	No	Yes	Yes	Yes
Cutoffs and estrangements	Yes	No	Yes	No	No	No
Generation to generation	Yes	Yes	Yes	Yes	No	Yes
Secrets as a means of protection	Yes	Yes	Yes	Yes	Yes	Yes

The data from this study supports some of the findings in the existing literature about family secrets. However, exploring the lived experiences of those keeping a family secret, the meanings found in keeping family secrets, and the functions that family secrets

serve, expands on what has been written about family secrets. This is particularly true of the challenges that are presented with illustrating each unique family secret within the different systems. The transcription and genogram excerpts also illustrate the various issues that are unique to the phenomenon of family secrets and the participants of this study.

## **CHAPTER V: DISCUSSION AND IMPLICATIONS OF THE STUDY**

Through this study the researcher explored the lived experiences of individuals who have kept a family secret. Through semi-structured interviews, the researcher was able to extract the meanings found within keeping a secret and the functions that secrets serve in families. The experiences shared by the five participants add to the existing literature on the phenomenon of keeping a family secrets and the impact on the emotional system.

The results of this study reflect what other researchers have affirmed about the functions of family secrets (Imber-Black, 1993; Vangelisti, 1994). However, detailed information about the experience of living with a secret brings light to issues that are shared amongst a group of people in the same emotional system. Because the emotional functioning of an individual is influenced by its relationship with other individuals and the environment (Kerr & Bowen, 1988), these findings shows a somewhat hermeneutic circle of how the participants' family secrets influence the emotional system and the function of those secrets in the system. While the emotional system is a major influence on human behavior, human behavior also influences the emotional system. This determines which secrets are kept in the family and with whom those secrets are kept.

The emotional systems suggests that humans are motivated to do things as a result of processes previously set in place for generations, as proved true for this study. For example, three of the five participants referred to an "island mentality" that influenced how secrets were kept in their respective families. Although not all participants were from the island, this is perhaps an area for future research; exploring the lived experience of family secrets in Afro-Caribbean families.

### **Strengths and Limitations**

The greatest strength of this study was the cooperation of the participants and their willingness to share their family secrets. They allowed the researcher to ask questions and explore areas that were not previously accounted for as new revelations surfaced during the interview. Some participants were also open about their particular secrets, others were candid about the hurt related to their family secrets.

Another strength related to the participants was the diversity in gender (3 females, 2 males), age range (26-65), and the age when the secret was revealed (13-30). In addition, all participants shared their own secret and some shared other family secrets that crossed over the generations. This helped to evaluate the multigenerational transmission process and how secrets are transferred from generation to generation.

An added strength of the study was the methodology. This qualitative format lent itself to the openness necessary for this type of exploration. Interpretative Phenomenological Analysis examines the lived experiences of individuals and explores how they make sense of it. While quantitative methods would not capture the essence of the phenomenon, other qualitative methods would also not capture the kinds of meanings found in the lived experiences. Interpretative Phenomenological Analysis allowed the researcher to interpret the participants experiences based on the participants own understanding of their unique experience.

As expected, there were some limitations of this study. The interview schedule presented some challenges due to the unique experiences presented during the interviews. Although the semi-structured questions were used as a guide to direct the conversation rather than facilitate it, the questions did not address every unique family secret and

experience. However, prepared questions allowed for the research questions to be addressed.

Another limitation is that this study did not include as much cultural or ethnic diversity, as four of the five participants were Afro-Caribbean. Participants were also from the same geographic location. Future research would benefit from the inclusion of a more diverse sample, particularly ethnically and culturally.

Although a smaller sample size is ideal for this methodology, it can be viewed as a limitation. However, with IPA it is about quality, rather than quantity. The primary focus is to obtain a detailed account of participants' experience, therefore a study like this benefits from a smaller number of participants where more focus can be given to unique perspectives. The information gleaned from the interviews is invaluable to this study and existing literature.

### **Self of the Researcher**

Bowen (1978) along with other pioneers in the field of marriage and family therapy view the work of therapists as instrumental to the therapeutic process and therefore believe in the concept of self-of-the-therapist, an extension of differentiation of self. Kerr (1981) explains that during this process, therapists are differentiating themselves from their clients' shared experience. Bowen (1978) maintains that the more secure therapists are with their personal issues, the more they are able to focus on the issues presented by the client. This process is considered vital in therapist training and development (Aponte, 1994; Timm & Blow, 1999).

The process of self-of-the-therapist was extended through this study as self-of-the-researcher. Husserl (1997) expounds on the need to bracket, or putting to one side,

through a series of reductions. This process is intended to, as Flowers et al. (2009) explain, “lead the inquirer away from the distraction and misdirection of their own assumptions and preconceptions, and back towards their experience of a given phenomenon” (p. 14). Similar to therapy where clients are the experts on their lives, these interviews were conducted with the reminder that the participants are the experts on their experiences. Therefore, close attention was given to participant’s words and pre-existing concerns and assumptions were bracketed.

### **Bracketing**

Smith et al. (2009) explain bracketing as a way to park preexisting notions or biases by focusing on the participant’s responses. Admittedly, there were moments when the researcher had more questions regarding specific secrets. During the genogram portion of the interview, Fay brought up an additional sister that wasn’t previously mentioned. She spoke of that sister in the past tense, so in order to get more information about the relationship the researcher asked a follow-up question to which Fay quickly retorted:

Fay: I don’t know. I don’t know anything. I don’t know where she is.

Researcher: Oh ok. So you’re not in communication with her?

Fay: Not now.

Immediate thoughts included:

- 1) Is this sister a result of an illicit relationship?
- 2) Why are they no longer in communication?
- 3) Is this sister a secret?



However, in an effort to respect the participant and what seemed to be her attempt to move on.

At another point during the drafting the genogram, Fay brought up her brother-in-law and that he was deceased. When asked about his age and cause of death, she matter-of-factly replied:

Fay:               Nope. They found him dead on the ground. And he had been dead for a couple of days.

Once again, I had more questions. Was this a mystery death or was this brother's lifestyle a secret?

There were also moments where there was a fine line between being a researcher and the desire to be a therapist and simply being curious. Towards the middle of the interview Fay became what appeared to be contemplative. She was asked about secret meaning:

Researcher:    What does it mean that this secret was kept? Whether it was the secret of the attempted suicide or the secret of, um, her pregnancy. Does it have any meaning? Or what does it mean to you, if it means anything?

She replied:

Fay:               What does it mean to me? (Long pause) It means that I wasn't wanted. You know...putting it bluntly.

During the long pause I wondered whether she was thinking of an answer to my question or did she not understand my question. But when she replied, it appeared that there was a little tremble in her voice and she turned her gaze straight ahead towards a wall. I was

sympathetic and wanted to ask more questions, but recognized the need for a minute of silence as we both were experiencing this moment in the interview.

Later in the interview Fay was asked about her experience with the secret:

Researcher: Can you describe any particular experiences related to your secret?

So did you have any difficult or traumatic experiences or even any good experiences that resulted from this family secret?

Fay: Well I think academically because I use [sic] to be really, really super smart. And once I had to deal with that, I focused more on that and you know, not talking about it or not being able to talk about it, not being able to confront the, the issue and understand at the time, um, life in general, I started trying to analyze the situation in whatever way I could. And it took my focus off of my God given talents. Because I was just trying to understand what life meant...and feeling badly, um, I contributed to somebody else's pain.

During this response Fay seemed emotional and got a little choked up towards the end. It seemed that she blamed herself for her mother's situation and causing her mother's pain. Therapeutic questions immediately flooded my mind, and I had to bracket those in order to concentrate on her response and the relevance of any follow-up questions to the research questions.

Notes were taken on a notepad during the interviews of any biases or preexisting concerns of the participants. This helped to pay particular attention to the participants'

words. During the analysis comments of the process were recorded in between the lines of the individual transcripts.

Smith et al. (2009) also explain that it's not that the researcher should not be curious or question, but that the questioning should be in response to what the participant is saying. By listening attentively, being sensitive to the participant during the interview, and the process of the self-of-the-researcher, ethical concerns were considered and observed.

### **Ethical Considerations**

As previously expressed, active listening was vital to completing the interviews. This included closely monitoring the effect of the interviews on each participant. Some of the material shared was quite emotional. Recalling the specifics for some of the interviewees was still very difficult, and the material still raw, despite how many years had passed since the experience. Paying attention to the question and the participant's responses (verbally and nonverbal) determined whether to continue with the line of questions, rephrase the question, or come back to the question.

Participants were informed at the onset of the interview that they could end questioning at any point or request referrals for counseling if necessary. All of the participants completed the full interview and none of the participants requested referrals. Keeping the ethical responsibilities for the participant at the forefront was a helpful and necessary reminder to be sensitive to the participants' needs during the interviews.

## Implications

### Future Research

Exploring the functions that a secret serves within a family can help to explain why individual members and families at large keep and maintain secrets. Future research could include interviews of three different family members from three different generations within a family (Figure 4). Phenomenology is an ideal methodology because it allows everyone the opportunity to validate their experience. As Creswell (2012) further explains, it also helps to “reduce individual experiences with a phenomenon to a description of the universal essence” (p. 76). This could in turn help families recognize the phenomenon of secrets within their own family and the phenomenon of secrets within all families.

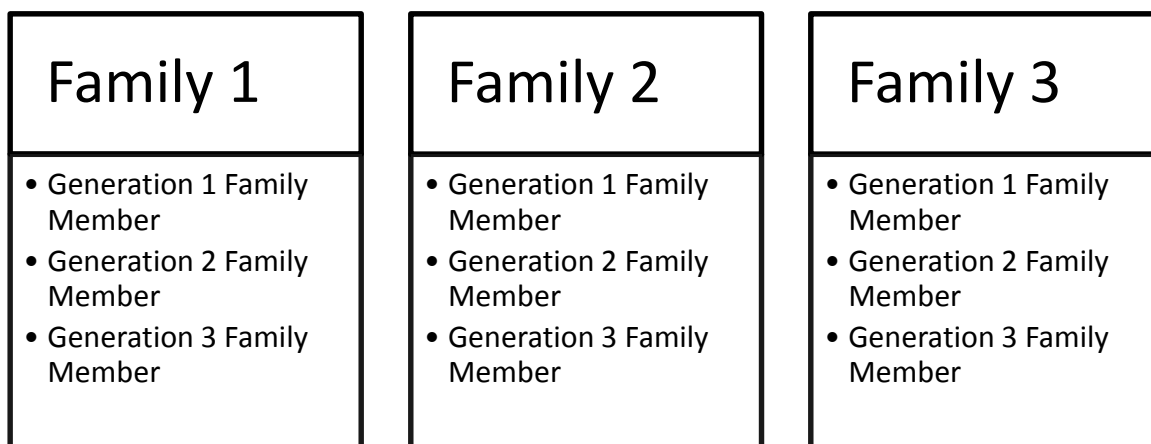

*Figure 10.* Sample selection of multigenerational family interviews. This figure illustrates suggested interview format with three different family members from three different generations within one family.

Other future research can include a concentration on the secret keeper and the many hats one must wear in order to keep a secret at bay. Some individuals fulfill this

role within their family where all secrets are funneled through them. An exploration into how one becomes the keeper of secrets and how that role has transferred throughout the generations, and the implications culturally, physically, mentally, and spiritually could add to the existing literature on family secrets and the functions they serve within different families.

Future research can also extend to how secrets are depicted in the genogram. When drafting a genogram, secrets are illustrated with a black triangle. Notes can be taken on the specific details of the secrets when compiling a hard copy of the genogram, however, the GenoPro software is limited to just the graphic of the triangle. It may be helpful to develop a way to illustrate the:

1. type (abuse, paternity, sexuality) of secret by different colors,
2. lines linking the different individuals involved in the secret, and
3. different roles of the family members (secret holder, the unaware, and the subject) involved in the secret.

Some of the participants shared that they had not previously shared their family secrets with anyone. Future research can also include studies of the effect of sharing family secrets with the researcher (or another individual) after holding onto it for an extended period of time. The assumption is that change has taken place as a result of the secret being shared. Further examination could explore how and what was evoked as a result of the interviews and the resulting changes to the system.

Although the primary function drawn from this study shows that participants keep family secrets to protect others, future research could also consider how holding onto personal or family secrets also serve the function of holding families together. The

different interviews explain how some participants view their family secrets negatively or positively. Therefore, the very thing that keeps some individuals away from their families, also keeps them close as a result of the environment in the emotional system.

### **For Marriage and Family Therapy**

When people talk about secrets, there is usually shame involved as a result. Secrets perpetuate shame and shame breeds secrecy (Imber-Black, 1998; Karpel, 1980). While the secret itself can cause shame for the secret keeper, it can indirectly contribute to feelings of shame in those who are unaware of the secret (Karpel, 1980).

Secrecy is also the bridge between privacy and shame (Mason, 1993). As previously expressed, secrets often create shame (Imber-Black, 1993). While some secrets are consciously kept private, some secrets may be repressed or hidden in the unconscious (Mason, 1993), potentially leading to anxiety and other symptoms. Secrets, as McGoldrick et al. (2008) express, “may distort family process for generations and lead to imbalances in functioning between the external picture presented to the world and internal realities of family relationship” (p. 194).

Some secrets are draped in shame and therefore can affect multiple aspects of one’s being. As one client of Imber-Black (1998) explains about the shame she felt growing up,

You could feel the shame that pervaded our family. You could taste it in the breakfast coffee. You could hear it in my parents’ voices, but never in their words. You could see it in the hunched-over way my brother walked. A lot of my energy went into trying to figure it out. (p. 25)

The source of shame may lie in the content of a secret or in the act of keeping a secret. Family rules may perpetuate the patterns and phenomena of secrets and shame within multigenerational families, thus creating a need for further exploration.

### **For Clinicians**

Kerr and Bowen (1998) state that “the way a therapist thinks about what energizes or drives the processes he observes in a family will govern what he addresses in therapy” (p. 11). This is especially true for family secrets. Papp (1993) explains that secrets shared within the family may be the most difficult to address in family therapy as a result of all members being “pledged to secrecy and are compelled to practice deception out of a sense of loyalty to the family” (p. 70). By incorporating a genogram and asking questions about family secrets, clinicians may gain further insight into clients’ lived experience and generational patterns. This can lead to a richer therapeutic process as clients explore the meanings they find in their family secrets and the functions their family secrets serve.

### **Concluding Thoughts**

This journey began with a genogram and was the result of a conversation about family secrets. At the infancy of this study I began to wonder about all of my family’s secrets and all the family secrets of the world. I was very excited as thoughts jumped here and there about what secrets are, how they are defined, and how that definition looks from individual to individual and family to family.

As I began to look at the phenomenon of family secrets, I became concerned with who would want to participate in the study. Who would want to open up and share their lives and be vulnerable about the very thing that should be unspoken? To my delight,

this study has met and exceeded my expectations for obtaining participants who were willing to share about their experience living with and keeping family secrets.

My hope for this study is that the experiences of the five participants will help others share their experience and breakdown some of the taboos that come with exposing the hidden. Some of the stories related to secret paternity, sexual abuse, sexuality, and domestic violence. Some left participants hurt, while others fostered new relationships.

McGoldrick et al. (2008) discuss that “society’s insidious pressure on families to distort their lives with lies and secrecy regarding any experiences that lie outside society’s life cycle norms” (p. 193) explains why the conversation about family secrets is important. This study helped to illuminate that pressure and the power of secrets in families. While some things are left better unsaid, some things that are shared lead to new hope not only for an individual, but for the generations to come.



## References

- Afifi, W. A., & Caughlin, J. P. (2006). A close look at revealing secrets and some consequences that follow. *Communication Research*, 33(6), 467-488.
- Aponte, H. (1994). How personal can training get? *Journal of Marital and Family Therapy*, 20, 3-15.
- Ashworth, P. (2007). In J. A. Smith (Ed.). *Qualitative psychology: A practical guide to research methods* (pp. 4-24). London, England: SAGE Publications Ltd.
- Bok, S. (1983) *Secrets: On the ethics of concealment and revelation*. New York, NY: Pantheon Books.
- Bowen, M. (1971). The use of family theory in clinical practice. In J. Haley (Ed.). *Changing families: A family therapy reader* (pp. 159-192). New York, NY: Grune & Stratton.
- Bowen, M. (1978). *Family therapy in clinical practice*. New York, NY: Jason Aronson.
- Bradshaw, J. (1995). *Family secrets: What you don't know can hurt you*. New York, NY: Bantam Books.
- Creswell, J. (2012). *Qualitative inquiry and research design: Choosing among five approaches* (3<sup>rd</sup> ed.). Thousand Oaks, CA: Sage.
- Fall, K. A., & Lyons, C. (2003). Ethical considerations of family secret disclosure and post-session safety management. *The Family Journal: Counseling and Therapy for Couples and Families*, 11(3), 281-285.
- Friedman, E. H. (1991). Bowen theory and therapy. In A. S. Gurman & D. P. Kniskern (Eds.). *Handbook of family therapy* (Vol. 2, pp. 134-170). New York, NY: Brunner/Mazel.
- Giorgi, A., & Giorgi, B. (2007). In J. A. Smith (Ed.). *Qualitative psychology: A practical guide to research methods* (pp. 25-52). London, England: SAGE Publications Ltd.

- Husserl, E. (1997). *Psychological and transcendental phenomenology and the confrontation with Heidegger (1927-1931)*. (T. Sheehan & R. E. Palmer, Trans.). Netherlands: Springer Netherlands. (Original work published 1927).
- Imber-Black, E. (1993). Secrets in families and family therapy: An overview. In E. Imber-Black (Ed.). *Secrets in families and family therapy* (pp. 66-85). New York, NY: W. W. Norton & Company, Inc.
- Imber-Black, E. (1998). The power of secrets. *Psychology Today*, 31(4), 50-53, 62.
- Imber-Black, E. (1998). *The secret life of families: Truth-telling, privacy, and reconciliation in a tell-all society*. New York, NY: Bantam Books.
- Karpel, M. A. (1980). Family secrets: Implications for research and therapy. *Family Process*, 19, 295-306.
- Kerr, M. E. (1981). Family systems theory and therapy. In A. S. Gurman & D. P. Kniskern (Eds.). *Handbook of family therapy* (pp. 226-264). New York, NY: Brunner/Mazel.
- Kerr, M. E. (1984). Theoretical base for differentiation of self in one's family of origin. *Family of Origin Applications in Supervision*, 2(2), 3-36.
- Kerr, M. E. (1988, September). Chronic anxiety and defining a self. *The Atlantic Monthly*, 35-58.
- Kerr, M. E. (1992). Physical illness and the family emotional system: Psoriasis as a model. *Behavioral Medicine*, 18(3), 101-113.
- Kerr, M. E., & Bowen, M. (1988). *Family evaluation*. New York, NY: Norton.
- Knauth, D. G. (2003). Family secrets: An illustrative clinical case study guided by Bowen family systems theory. *Journal of Family Nursing*, 9(3), 331-344.
- Mason, M. J. (1993). Shame: Reservoir for family secrets. In E. Imber-Black (Ed.). *Secrets in families and family therapy* (pp. 29-43). New York, NY: W. W. Norton & Company, Inc.

- McCurdy, K. G., & Murray, K. C. (2003). Confidentiality issues when minor children disclose family secrets in family counseling. *The Family Journal: Counseling and Therapy for Couples and Families*, 11(4), 393-398.
- McGoldrick, M., Gerson, R., & Petry, S. (2008). *Genograms: Assessment and intervention* (3<sup>rd</sup> ed.). New York, NY: Norton.
- Minuchin, S. (1974). *Families & family therapy*. Cambridge, MA: Harvard University Press.
- Noone, R. (1989). Systems thinking and differentiation of self. *Center for Family Communication Consultation Review*, 1(1), 1-3.
- Papp, P. (1993). The worm in the bud: Secrets between parents and children. In E. Imber-Black (Ed.). *Secrets in families and family therapy* (pp. 66-85). New York, NY: W. W. Norton & Company, Inc.
- Polkinghorne, D. E. (1995). Narrative configuration in qualitative analysis. *Qualitative Studies in Education*, 8, 5-23.
- Satir, V., Stachowiak, J., & Taschman, H. A. (1975). *Helping families to change*. New York, NY: Jason Aronson, Inc.
- Secret. (2014). In *Merriam-Webster.com*. Retrieved July 1, 2014, from <http://www.merriam-webster.com/dictionary/secret>
- Smith, J. A., Flowers, P., & Larkin, M. (2009). *Interpretative phenomenological analysis: Theory, method and research*. London, England: SAGE Publications Ltd.
- Smith, J. A., & Osborn, M. (2007). Interpretative phenomenological analysis. In J. A. Smith (Ed.). *Qualitative psychology: A practical guide to research methods* (pp. 53-80). London, England: SAGE Publications Ltd.

Timm, T. M., & Blow, A. J. (1999). Self-of-the-therapist work: A balance between removing restraints and identifying resources. *Contemporary Family Therapy, 21*(3), 331-351.

Vangelisti, A., Caughlin, J., & Timmerman, L. (2001). Criteria for revealing secrets. *Communication Monographs, 68*(1), 1-27.

Vangelisti, A. L. (1994). Family secrets: Forms, functions and correlates. *Journal of Social and Personal Relationships, 11*(1), 113-135.

Vangelisti, A. L. & Caughlin, J. P. (1997). Revealing family secrets: The influence of topic, function, and relationships. *Journal of Social and Personal Relationships, 14*(5), 679-705.

## Appendices

## Appendix A

### Mental Health Professional and Clergy Member Invitation

Dear Mental Health Professional or Clergy Member,

My name is Tracy Oliver, LMFT and I am in the marriage and family therapy (MFT) doctoral program at Nova Southeastern University. In order to fulfill partial requirements for my doctorate degree, I am conducting a research study to contribute to the body of literature in the marriage and family therapy field. This research will examine in detail the personal lived experience of those currently keeping or who have kept family secrets. Another purpose of the research is to explore how participants make sense of their experience and what meaning was found. Therefore, through this research study, I seek to explore the views of five to seven individuals from different families. Family secrets can be a driving force, whether explicitly or implicitly, for many seeking therapy. By exploring and mapping the functions of multigenerational family secrets, I hope to conduct a study to examine in detail how participants are making sense of their lived experience with holding a family secret.

#### **What does this study involve?**

The study involves the researcher interviewing the participant face-to-face for approximately two to three hours and audio recording the entire interview. Recording of interviews would only take place following the participant's signed consent to participate in the study and record the interview. The interview would occur at a time and place that is convenient to the participant and would consist of being asked questions about his or her experience of living with a family secret. In order for participants to be eligible, they must be at least 18 years old and English speaking. It is not necessary to disclose the family secret in order to participate in the study. The purpose of the research is to gain an understanding of the experience of holding the family secret.

If you know someone who may be interested in participating, have any questions regarding the requirements for participation, or any other questions regarding the research study in general, please contact me via telephone at 954-854-0511 or email at [saintelu@nova.edu](mailto:saintelu@nova.edu). Thank you for your consideration in participating in this study and/or nominating someone who you believe would also be suitable for this study.

Sincerely,

Tracy Oliver, LMFT

## **Appendix B**

### **Adult/General Informed Consent**

#### Consent Form for Participation in the Research Study Entitled Mapping the Hidden: A Family Systems Approach to Multigenerational Family Secrets

Funding Source: None

IRB protocol #:

Principal investigator  
Tracy Oliver, MS (Ph.D. Candidate)  
4103 Wimbledon Drive  
Cooper City, FL 33026  
954-854-0511

Co-Investigator  
Chris Burnett, Psy.D.  
3301 College Avenue  
Ft. Lauderdale, FL 33314  
954-262-3010

For questions/concerns about your research rights, contact:  
Human Research Oversight Board (Institutional Review Board or IRB)  
Nova Southeastern University  
(954) 262-5369/Toll Free: 866-499-0790  
IRB@nsu.nova.edu

#### **What is the study about?**

This study involves research seeking to identify the functions that secrets may have served in participants multigenerational families. The intention of the study is to:

- 1) Explore the lived experience of individuals holding a family secret, and
- 2) Analyze the meaning found in holding a family secret.

#### **Why are you asking me?**

You were either selected as a participant based on a being informed by someone of the study or are being invited to take part in this research because we feel that your experience related to the study's topic can contribute much to our understanding and knowledge of multigenerational family secrets. There will be approximately five to seven participants from different families.

#### **What will I be doing if I agree to be in the study?**

We are asking you to help us learn more about multigenerational family secrets. We are inviting you to take part in this research project. If you accept, you will be asked to participate in an interview with the Principal Investigator.

During the interview, the Principal Investigator will meet with you in a comfortable setting, mutually agreed upon. If it is better for you, the interview can take place in your residence. Interviews can last anywhere between two and three hours. If an additional interview is necessary, the researcher will schedule a follow-up with the participant; preferably within a week. If you do not wish to answer any of the questions during the interview, you may say so and the interviewer will move on to the next question. No one else but the Principal Investigator will be present unless you would like someone else to be there. However, the Principal Investigator asks that minors not be present. Anyone present during the interview must also complete the Informed Consent form.

**Is there any audio or video recording?**

This research project will include audio recording of the interview with an Olympus VN-7200 Digital Voice Recorder. This audio recording will be available to be heard by the researcher, the IRB, and the dissertation chair. The recording will be transcribed by the Principal Investigator. The recording will be kept securely within a locked safe within a locked office within the Principal Investigator's residence. Recordings will be maintained for 36 months after the completion of the study and then deleted from the digital voice recorder. Because your voice will be potentially identifiable by anyone who hears the recording, your confidentiality for things you say on the recording cannot be guaranteed although the researcher will try to limit access to the recording as described in this paragraph.

**What are the dangers to me?**

You will be asked to share some personal and confidential information, and you may feel uncomfortable talking about some of the topics. You do not have to answer any question or take part in the interview if you do not wish to do so. You do not have to give any reason for not responding to any question, or for refusing to take part in the interview. The procedures or activities in this study may have unknown or unforeseeable risks.

If you have any questions about the research, your research rights, or have a research-related injury, please contact:

Principal Investigator  
Tracy Oliver  
saintelu@nova.edu  
954-854-0511

Co-Investigator  
Chris Burnett, Psy.D.  
burnett@nova.edu  
954-262-3010

You may also contact the IRB at the numbers indicated above with questions as to your research rights.

**Are there any benefits for taking part in this research study?**



There are no direct benefits.

**Will I get paid for being in the study? Will it cost me anything?**

There are no costs to you or payments made for participating in this study.

**How will you keep my information private?**

The research being done in the community may draw attention and if you participate you may be asked questions by other people in the community. Your information will not be shared with anyone outside of the research team. The information that is collected from this research project will be kept confidential. To ensure security and confidentiality, any identifying information (such as your name) will be replaced with an assigned number. Only the researcher will know what your number is and that information will be secured with a lock and key. It will not be shared with or given to anyone.

The data will be retained for a minimum of 36 months from the conclusion of the study, as required by the NSU IRB. After the minimum of 36 months, the audio recordings will be deleted from the digital audio recorder and all paper documents, including consent forms, demographic questionnaires, and transcriptions will be shredded. All information obtained in this study is strictly confidential unless disclosure is required by law. The IRB, regulatory agencies, the dissertation chair (advisor) may review research records.

**What if I do not want to participate or I want to leave the study?**

You have the right to leave this study at any time or refuse to participate. If you do decide to leave or you decide not to participate, you will not experience any penalty or loss of services you have a right to receive. If you choose to withdraw, any information collected about you **before** the date you leave the study will be kept in the research records for 36 months from the conclusion of the study but you may request that it not be used.

**Voluntary Consent by Participant:**

By signing below, you indicate that

- this study has been explained to you
- you have read this document or it has been read to you
- your questions about this research study have been answered
- you have been told that you may ask the researchers any study related questions in the future or contact them in the event of a research-related injury
- you have been told that you may ask Institutional Review Board (IRB) personnel questions about your study rights
- you are entitled to a copy of this form after you have read and signed it
- you voluntarily agree to participate in the study entitled “Mapping the Hidden: A Family Systems Approach to Multigenerational Family Secrets”

Participant's Signature: \_\_\_\_\_ Date:

\_\_\_\_\_

Participant's Name: \_\_\_\_\_ Date:  
\_\_\_\_\_

Signature of Person Obtaining Consent:  
\_\_\_\_\_

Date: \_\_\_\_\_

### **Appendix C**

#### **Interview Schedule: Participant's Genogram and Experience of Family Secret**

##### **Interview Questions**

##### **a) Genogram Questions**

i) What is your mother's mother's name?

(1) Is she deceased? Age?

ii) What is your mother's father's name?

(1) Is he deceased? Age?

iii) How many children did your mother's parents have together?

iv) What is your father's mother's name?

(1) Is she deceased? Age?

v) What is your father's father's name?

(1) Is he deceased? Age?

vi) How many children did your father's parents have together?

vii) Are you aware of any other pregnancies, miscarriages, stillbirths, or abortions?

viii) Who in your family is aware of the secret?

ix) How does each member view the secret?

x) Does anyone else in the family have this or another secret?

##### **b) IPA Questions**

i) Can you please tell me how you first became aware of your family secret?

ii) How was the secret revealed?

(1) Probe question: How did what was once a secret become revealed?

iii) Was it explosive like a bomb was dropped?

iv) When did you become aware of the secret? What was happening in your life at the time?

v) What does this family secret mean to you?

vi) Please tell me about your experience with your family secret?

(1) Probe question: What kind of effect did it have?

vii) Please tell me about your experience holding your family secret?

viii) Can you describe any particular experiences in your life related to your family secret?

(1) Probe question: Any difficult or traumatic experiences? Any good experiences?

ix) How does your family view the family secret?

x) Why do you think this secret was considered a secret?

xi) Why did your family keep this a secret?

xii) What message was transferred from generation to generation to maintain/keep the secret?

xiii) What function did the secret have in your family?

### **Closing Question**

Thank you for all that valuable information, is there anything else you'd like to add before we end?

## Appendix D

### Revised Interview Schedule: Participant's Genogram and Experience of Family

#### Secret

#### Interview Questions

##### a) Genogram Questions

i) What is your mother's mother's name?

(1) Is she deceased? Age?

ii) What is your mother's father's name?

(1) Is he deceased? Age?

iii) How many children did your mother's parents have together?

iv) What is your father's mother's name?

(1) Is she deceased? Age?

v) What is your father's father's name?

(1) Is he deceased? Age?

vi) How many children did your father's parents have together?

vii) Are you aware of any other pregnancies, miscarriages, stillbirths, or abortions?

##### b) IPA Questions

i) How do you define a secret?

ii) What is the family secret or who is the secret about?

iii) Can you please tell me how you first became aware of your family secret?

iv) What was happening in your life at the time?

v) How was the secret revealed?

(1) Probe question: How did what was once a secret become revealed?

- vi) Was it explosive like a bomb was dropped?
- vii) Who in your family is or was aware of the secret?
- viii) How does each member view the secret?
- ix) Does anyone else in the family have this or another secret?
- x) What does this family secret mean to you?
- xi) Please tell me about your experience living with your family secret?
- (1) Probe question: What kind of effect did it have?
- xii) Please tell me about your experience holding your family secret?
- xiii) Can you describe any particular experiences in your life related to your family secret?
- (1) Probe question: Any difficult or traumatic experiences? Any good experiences?
- xiv) How does your family view the family secret?
- xv) Why do you think this secret was considered a secret?
- xvi) Why did your family keep this a secret?
- xvii) What message was transferred from generation to generation to maintain/keep the secret?
- xviii) What function did the secret have in your family?

### **Closing Question**

Thank you for all that valuable information, is there anything else you'd like to add before we end?

## Appendix E

### Individual Superordinate Themes

<b>Table of Themes: Sam</b>			
<b>Superordinate Themes</b>	<b>Emergent Themes</b>	<b>Keywords</b>	<b>Line Number</b>
Secrets as a means of protection	Protecting son from the effects of the secret	“I wouldn’t want my son to feel abandoned”	112
	Protecting her sisters from the secret	“‘cause I’m the oldest”	240
Bomb drop	Experience of the secret revealed	“So it would’ve been a bomb that dropped”	147
Normalization	Normalizing secret	“So I guess it, it kind of normalized my situation”	205
		“they had had a similar situation”	207
Island Mentality	Cultural norms	“And culturally, it’s, uh, not out of the norm”	208
Generational transmission of secrets	Children are seen, not heard Children have no voice	“I was raised where children are seen and not heard”	131
		“I didn’t have a voice”	131
		“Like I said, children are seen and not heard”	228
Keep it in the family	Keep it in the family	“what happens in this house, stays in this house”	229
		“I was told that what happens here stays here”	266
Anxiety	Effects of the experience	“I’m always apprehensive about men”	244
		“what it does to me is hold everyone accountable”	274

New trends	Wanting something different for son Open discussion No secrets	“I am nothing like that with my son” “whatever happens here is open for discussion” “there shouldn’t be a secret”	269 274
------------	--	---	------------

<b>Table of Themes: Brad</b>			
<b>Superordinate Themes</b>	<b>Emergent Themes</b>	<b>Keywords</b>	<b>Line Number</b>
What's in a secret?	Do not share Element of shame Potential to strain relationships	"something that you do not share with everyone"	335
		"generally has a [sic] element of either shame"	337
		"the potential to have a strain on relationships"	339
Faith and community	Prominence in community Societal norms Church	"my stepfather was a very prominent Jamaican"	394
		"it was just part of society and you keep this kind of things a secret"	593
		"Don't let these things be known"	594
		"my grandmother is very prominent in her church"	612
		"my mom can't be married to this prominent person"	625
Bomb	Mixture of emotions Questioning why Shock	"It was more like wow"	413
		"More questioning"	413
		"A little bit of shock"	416
Acceptance	Acceptance Embraced	"They were very welcoming"	439
		"my dad's siblings are very welcoming"	590
		"I'm accepted by my dad's kids"	657
		"accepted and embraced"	668
Good to not know	Good life Opportunities Travel	"I actually had a really good life"	480
			498



	Best schools	<p>“the opportunities that I did have, to travel, and to have a good education”</p> <p>“I got to travel the world”</p> <p>“Went to all the best schools”</p>	<p>563</p> <p>564</p>
Negative effects	<p>Lost time</p> <p>Patterns</p> <p>Biological predisposition</p> <p>No full siblings</p>	<p>“I feel like there was a lot of time lost”</p> <p>“I feel I could’ve spent that time getting to know him”</p> <p>“I felt a lot of time was lost”</p> <p>“patterns of my dad’s decisions, if I’ll also repeat those”</p> <p>“you’re predisposed to certain behaviors”</p> <p>“time lost with my siblings”</p> <p>“I don’t have any full siblings”</p> <p>“never will in my view have the opportunity to have that type of sibling camaraderie”</p>	<p>482</p> <p>487</p> <p>490</p> <p>572</p> <p>578</p> <p>583</p> <p>644</p> <p>653</p>
Meaning	<p>Love</p> <p>Sacrifice</p> <p>Necessity</p>	<p>“it meant to me that someone wanted me to have a better”</p> <p>“my mom felt that was the best thing for her and for me at the time”</p> <p>“sign of love”</p> <p>“sacrifices to some extent”</p> <p>“that secret was absolutely necessary”</p>	<p>497</p> <p>500</p> <p>501</p> <p>501</p> <p>503</p>

Burden of secret keeping	Difficult Protecting someone else's secret	"it was very difficult" "constant sidestepping of the issue"	544 546
Emotional effects	Shame Disgrace	"that definitely would have been a shameful thing for my mom" "it would've been a shame that this famous guy, his wife cheated on him" "the shame and disgrace that would come as a result"	609 613 618
Secrets as a means of protection	Protection Preservation Saving face	"it was also used as a means of protection" "not facing their failures" "personal preservation of a look or a façade"	619 632 635
Island Mentality	Cultural norms Infidelity Keeping Secrets Outside children	"this is quite prominent in Jamaican society" "Infidelity and you know" "keeping the secret" "outside kid syndrome"	640 642 642 643

<b>Table of Themes: Rebecca</b>			
<b>Superordinate Themes</b>	<b>Emergent Themes</b>	<b>Keywords</b>	<b>Line Number</b>
What's in a secret?	Don't want others to know Not sharing personal information	"something that you don't want to let people know"	485
		"saving face"	487
		"not putting your business out there"	487
Negative effects	Negative views of father Negative views of father's family	"He was immature"	176
		"he was just childish"	350
		"gosh this guy is really immature"	392
		"He was always in some type of trouble"	421
		"they're kind of sick and twisted"	501
		"he is so immature and stupid"	850
Turning a new leaf	Grandmother changed Positive memories of grandmother	"There's nothing good. It's evil and disgusting and death and nastiness"	873
		"my grandmother changed when I was born"	199
Saving face	Saving face Wearing a mask	"I remember my grandmother humming a hymn and always cooking"	301
		"most angry and horrible parents or people inside the house, but as soon as they leave"	226
		"She wore a fake pink engagement ring"	245
		"she still wore like the fake pink, like plastic"	252

		“to save face she said no and left everything”	272
Island mentality	Island norms Keeping secrets	“She was very tight-lipped”	264
		“you know island people sometimes”	265
		“she just never let things out”	267
		“because their island mentality, the grandmother blamed her”	569
		“you sort of get used to coming from the different island mentalities”	890
		“to have whisperings and hear what’s true, what’s not true and hear from different family members”	893
		“tight-lipped, keeping your mouth shut”	899
		“you’re just hush-hush I suppose”	901
Cutoffs	Estrangements Distancing self	“You don’t go outdoors and say what’s going on indoors”	1082
		“I still remember that he was abusive towards my mom”	322
		“I’ll say like, ‘tell him I’m not here’”	334
		“That’s estranged”	339
		“I stopped talking to that side of the family”	363
		“I’m estranged from them”	514
		“I stopped talking to him from that day on”	763

		<p>“I just have no interest in that”</p> <p>“I don’t talk to him anymore”</p> <p>“I don’t want anything to do with my father or that side of the family”</p>	<p>846</p> <p>871</p> <p>872</p>
Consequences of secret revealed	<p>Punishment</p> <p>Lied about</p> <p>Mother hurt</p>	<p>“my mom beat me”</p> <p>“he told her everything I said was a lie”</p> <p>“She was really upset”</p> <p>“backed him and said she was a liar”</p> <p>“said she was like a lying whore”</p>	<p>692</p> <p>742</p> <p>784</p> <p>816</p> <p>823</p>
What family means	<p>Mom is safety place</p> <p>What family means</p> <p>Mom is family</p>	<p>“Come to her if I need to”</p> <p>“I know what I don’t want and what family means”</p> <p>“I consider my family my mother”</p>	<p>778</p> <p>992</p> <p>1012</p>
Emotional effects	<p>Shame</p> <p>Embarrassment</p>	<p>“I just felt a lot of shame”</p> <p>“blame themselves and self-hatred”</p> <p>“shameful thing and embarrassing”</p> <p>“I felt nasty. Like I was dirty.”</p>	<p>964</p> <p>967</p> <p>968</p> <p>1110</p>
Secrets as a means of protection	<p>Didn’t want to hurt mother</p> <p>Aunt wanted to keep family intact</p> <p>Didn’t want to hurt mom’s feelings</p>	<p>“I knew it would’ve kind of torn her apart”</p> <p>“I don’t know if she just wanted to keep her family together”</p> <p>“I just didn’t want to hurt her feelings”</p> <p>“I knew she’d be upset”</p>	<p>975</p> <p>1105</p> <p>1110</p> <p>1113</p>

<b>Table of Themes: Ron</b>			
<b>Superordinate Themes</b>	<b>Emergent Themes</b>	<b>Keywords</b>	<b>Line Number</b>
What's in a secret?	Don't want outside Keep to yourself	"obviously something you don't want people outside"	223
		"there are secrets that you keep all to yourself"	224
		"Then there are secrets you are comfortable to share"	228
Bomb	Experience of secret reveal	"I was definitely in shock"	318
		"always kind of knew, but we've been kind of in denial"	336
		"I was definitely hurt when I first found out"	392
Meaning of the secret	Brother doesn't trust	"he couldn't trust me with that secret he had"	393
Negative effects	Barrier Hurt	"I did feel that that put a barrier in our relationship"	396
		"I was hurt that he couldn't tell me"	398
Secrets as a means of protection	Keep it in the family Protecting others from the secret	"I definitely was against him coming out to our uncle and aunt"	409
		"making this circle bigger before the important people found out"	411
		"I was concerned about their feelings"	412
Burden of secret keeping	Burden of secret keeping Loyalty	"knowing this is um you know, hanging above my head"	423

		<p>“that feeling carrying this burden now”</p> <p>“forced to keep my mouth shut about it”</p> <p>“It must’ve been very hard for him to keep”</p>	<p>426</p> <p>427</p> <p>481</p>
Faith and community	Faith Church	<p>“being raised in a Christian home”</p> <p>“it was always church related activity”</p> <p>“knew what the Bible says about being homosexual”</p> <p>“knew that my parents were devout Christians”</p>	<p>473</p> <p>474</p> <p>474</p> <p>475</p>
New perspective	Empathy Wishing he was there for his brother	<p>“I have been more understanding of him”</p> <p>“I don’t know the pain”</p> <p>“ease whatever suffering he was going through”</p>	<p>432</p> <p>439</p> <p>445</p>
Burden released	Not a secret Live freely and openly	<p>“it’s not much of a secret anymore”</p> <p>“why would they keep it a secret if he’s not making an effort”</p> <p>“live out that lifestyle freely and openly”</p>	<p>454</p> <p>466</p> <p>485</p>

<b>Table of Themes: Fay</b>			
<b>Superordinate Themes</b>	<b>Emergent Themes</b>	<b>Keywords</b>	<b>Line Number</b>
What's in a secret?	Keep yourself Don't share Disgrace	"Something that you keep yourself"	196
		"Not share with anybody else"	196
		"Because it was a disgrace"	310
Faith and community	Community role Church Faith	"they were prominent people"	241
		"came from a family that was prominent"	312
		"actively involved in church"	325
		"And they were always in leadership"	326
Meaning of the secret	Means unwanted	"It means that I wasn't wanted"	275
		"I know that she didn't want me"	339
Lived Experience	Emotional effects of secret Negative effects of the secret	"It was a disgrace"	240
		"my grandaunt took her because it was a disgrace"	243
		"That you're not really wanted"	279
		"not talking about it or not being able to talk about it"	301
		"it took my focus off of my God given talents"	304
Multigenerational transmission	Children don't have a voice	"feeling badly"	305
		"I was a kid. They didn't figure it was necessary"	315
Secrets as a means of protection	Protecting mother from feeling bad Protecting mother from experiencing pain	"I don't want anybody to think bad of her"	290
			291



		<p>“I don’t want her to experience any pain from it “</p> <p>“I want to protect her”</p>	
New hope	<p>Helping others</p> <p>Empathy for mother’s situation</p>	<p>“for unwed mothers, I’ll always be an advocate for them”</p> <p>“I can imagine the pain that they feel”</p> <p>“I always want to be there for unwed mothers”</p>	<p>293</p> <p>294</p> <p>296</p>

## Appendix F

### Participant Genograms

#### Sam's Genogram

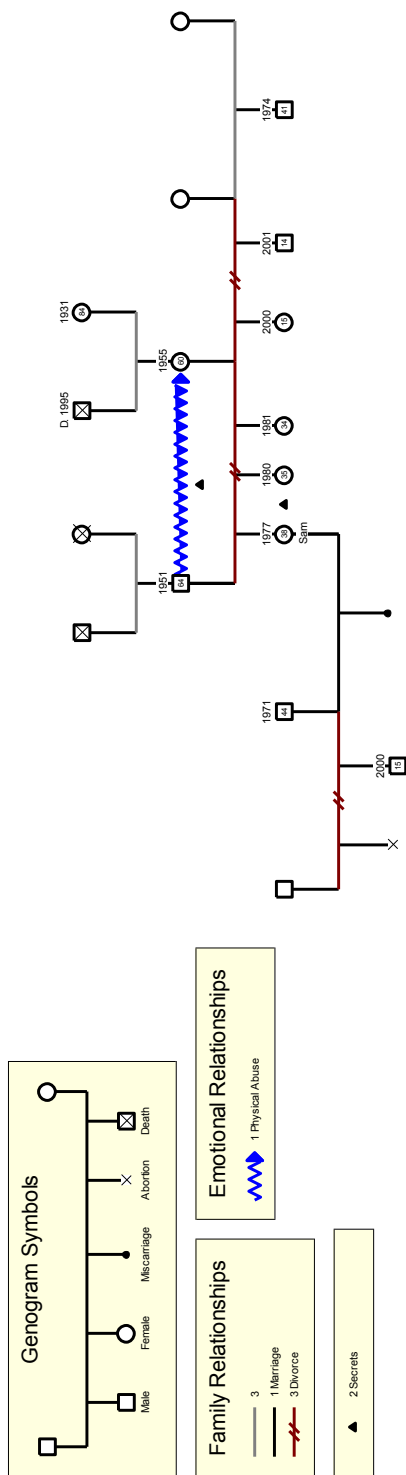

# Brad's Genogram

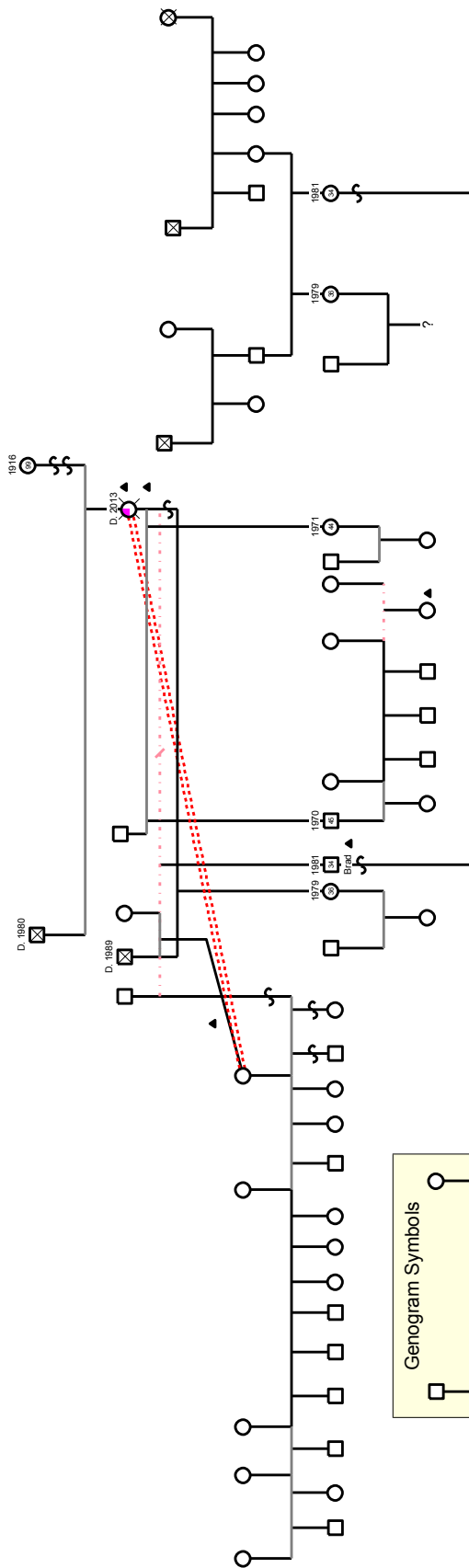

**Genogram Symbols**

- Male
- Female
- Unknown Gender
- Death

**Family Relationships**

- 10 Relationships
- 8 Marriage
- 1 Love Affair
- 1 Love Affair and separation

**Emotional Relationships**

- 1 Discort / Conflict

- 8 Immigration
- 5 Secrets
- 1 Cancer



# Ron's Genogram

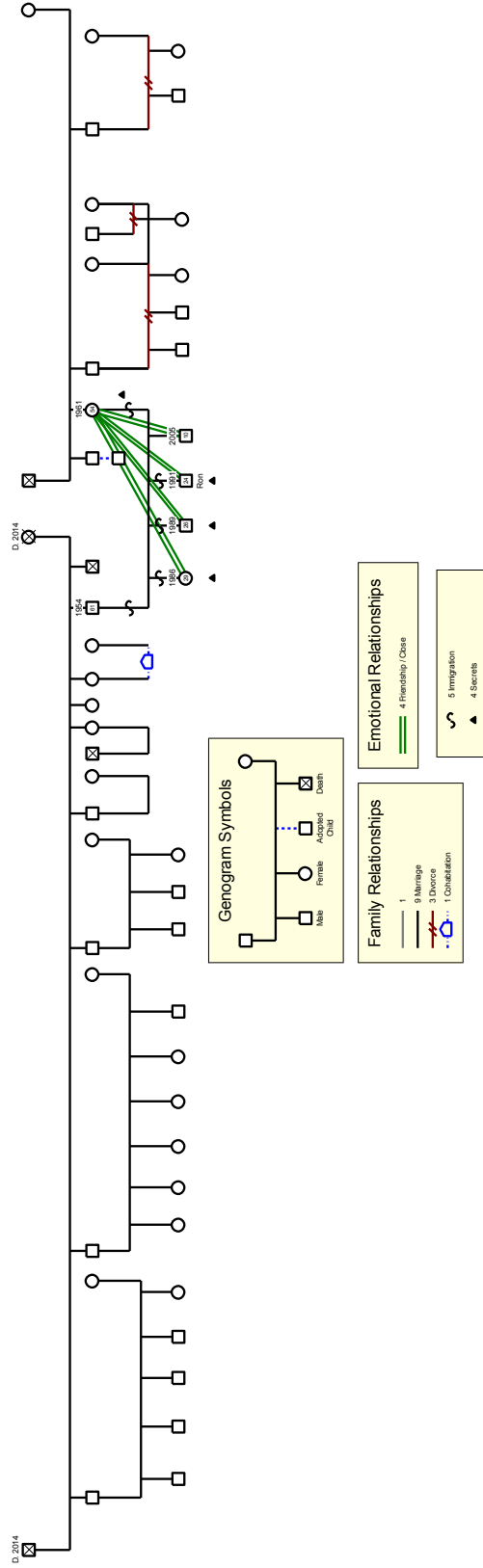

### Fay's Genogram

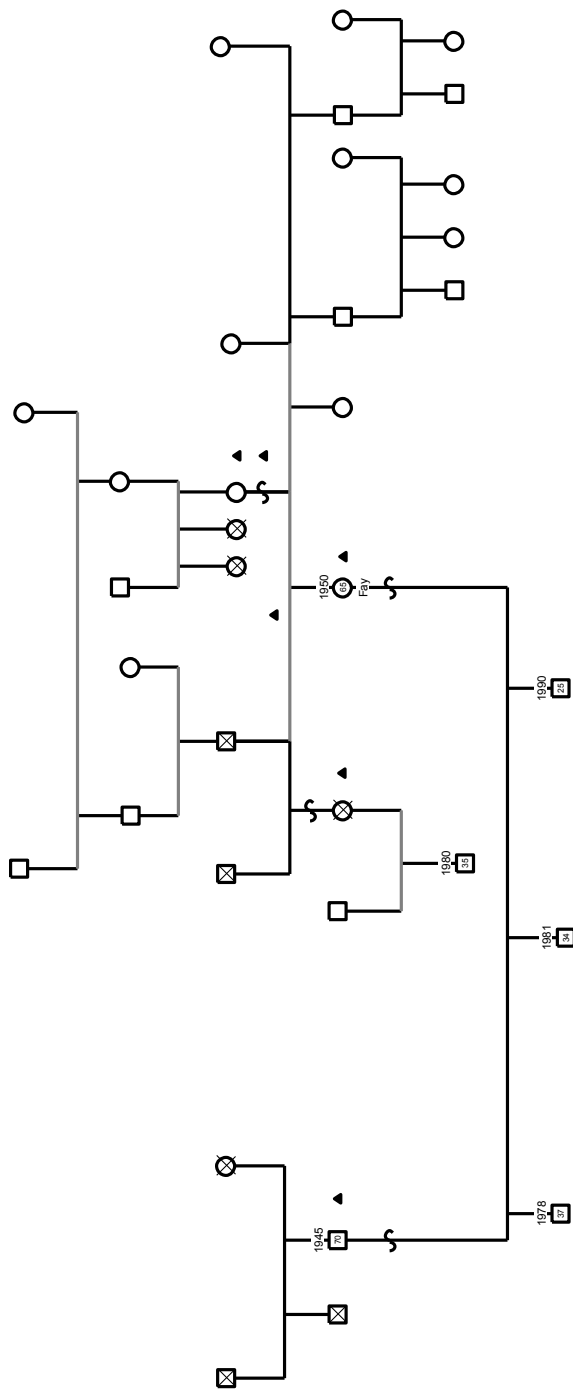

**Genogram Symbols**

- Male
- Female
- ⊗ Death

**Family Relationships**

- Relationships
- == Marriage

- S Immigration
- ▲ Secrets

### **Biographical Sketch**

Tracy Oliver, a native of South Florida, grew up playing the piano and other woodwind instruments and aspired to be a medical doctor in order to help others. After completing high school, she attended Florida State University and planned to major in biology when she realized after a year that the biological medical field was not for her. After completing a bachelor's degree in Fashion Merchandising, Tracy pursued a career in retail business management. She went on to complete her master's in Business Administration. During that time Tracy volunteered as a peer counselor and educator for a women's center and was reminded of her lifelong desire to help others. This inspired a search into counseling degrees at which was introduced to the marriage and family therapy field. She was convinced that this program was the right fit and therefore pursued a master's in family therapy.

During the program Tracy interned at different facilities, which included an outpatient rehabilitation center for adolescents and young adults. She also attended a presentation led by a former graduate about family law and how mental health practitioners can assist in family mediation. This sparked another interest. After completing the master's program, she attended training and became a certified State Family Mediator.

By now Tracy knew that she would pursue her doctorate in family therapy and decided that it would be best to pursue a career helping families; therefore she resigned from her full-time position in the business field. After her acceptance into the doctoral program, Tracy began working as a youth counselor for the local sheriff's office and continued to work towards state licensure. This experience showed her how she can help

others in the mental health field and furthered her desire to work with individuals and families.

During the doctoral program Tracy has experienced much change, including becoming a wife and mother. This addition of family led to exploration of lineage and family relationships and ultimately led to her dissertation research topic. Tracy is a licensed marriage and family therapist and works with at an interfaith organization that provides spiritually-sensitive psychotherapy in South Florida.